

UNITED STATES PATENT AND TRADEMARK OFFICE

---

BEFORE THE PATENT TRIAL AND APPEAL BOARD

---

POLYCOM, INC.,  
Petitioner

v.

DIRECTPACKET RESEARCH, INC.,  
Patent Owner

---

IPR2019-01233  
Patent 7,773,588 B2

---

Before BRYAN F. MOORE, SHEILA F. McSHANE, and  
RUSSELL E. CASS, *Administrative Patent Judges*.

McSHANE, *Administrative Patent Judge*.

DECISION  
Final Written Decision  
Determining All Challenged Claims Unpatentable  
Granting Patent Owner's Motion to Seal  
*35 U.S.C. § 318(a)*

## I. INTRODUCTION

We have jurisdiction to hear this *inter partes* review under 35 U.S.C. § 6. This Final Written Decision is issued pursuant to 35 U.S.C. § 318(a). For the reasons discussed herein, we determine that Petitioner has shown by a preponderance of the evidence that all of the challenged claims of U.S. Patent No. 7,773,588 B2 (Ex. 1001, “the ’588 patent”) are unpatentable.

### *A. Procedural Background*

Polycom, Inc. (“Petitioner”)<sup>1</sup> filed a Petition requesting *inter partes* review of claims 1–23 (“the challenged claims”) of the ’588 patent pursuant to 35 U.S.C. §§ 311–319, along with the supporting Declaration of Dr. Tal Lavian. Paper 1 (“Pet.”); Ex. 1002. directPacket Research, Inc. (“Patent Owner”) filed a Preliminary Response to the Petition, along with the supporting Declaration of Dr. Kevin Jeffay. Paper 8; Ex. 2001. With authorization (Paper 14), Petitioner filed a pre-institution Reply to Patent Owner’s Preliminary Response (Paper 15), with Patent Owner filing a pre-institution Sur-Reply (Paper 17). Pursuant to 35 U.S.C. § 314(a), on January 13, 2020, we instituted *inter partes* review on the grounds of:

---

<sup>1</sup> Petitioner identifies Plantronics, Inc., as another real party-in-interest. Pet. 2.

<b>Claims Challenged</b>	<b>35 U.S.C. §</b>	<b>Reference(s)/Basis</b>
1–23	103(a) <sup>2</sup>	Ress <sup>3</sup>
1–23	103(a)	Ress, Doyle <sup>4</sup>

Pet. 5; Paper 21 (“Inst. Dec.”).

Patent Owner filed a Patent Owner Response (“PO Resp.”), along with the Declaration of Dr. Kevin Jeffay in Support of the Response. Paper 30; Ex. 2009. Petitioner filed a Reply (“Pet. Reply”) to the Patent Owner Response, with the supporting Reply Declaration of Dr. Tal Lavian. Paper 46; Ex. 1017. Patent Owner filed a Sur-Reply (“PO Resp. Sur-Reply”). Paper 54.

With the Board’s leave (Paper 60), Petitioner filed a supplemental brief on claim construction (Paper 62, “Pet. Suppl. Br.”), and Patent Owner filed a supplemental brief on the same (Paper 61, “PO Suppl. Br.”). Petitioner filed a responsive supplemental brief on claim construction (Paper 63, “Pet. Suppl. Resp. Br.”), and Patent Owner filed a supplemental responsive brief (Paper 64, “PO Suppl. Br.”).

An oral hearing was held on October 20, 2020. A transcript of the hearing is included in the record. Paper 65 (“Tr.”).

---

<sup>2</sup> The Leahy-Smith America Invents Act, Pub. L. No. 112-29, 125 Stat. 284 (2011) (“AIA”), amended 35 U.S.C. § 103. Because the challenged claims of the ’588 patent have an effective filing date before the effective date of the applicable AIA amendment, we refer to the pre-AIA version of 35 U.S.C. § 103.

<sup>3</sup> US 6,885,658 B1, filed on February 18, 2000, issued April 26, 2005, claiming priority to Provisional Application No. 60/137,867, filed on June 7, 1999. Ex. 1004.

<sup>4</sup> US Pub. No. 2002/0133588 A1, published September 19, 2002. Ex. 1005.

*B. Related Proceedings*

At the time of the Petition filing, Petitioner identified *directPacket Research, Inc. v. Polycom, Inc.*, 2:18-cv-00331-AWA-RJK (E.D. Va.) as a related matter. Pet. 2–3. At the time of the filing of Mandatory Notices, Patent Owner indicated that *directPacket Research, Inc. v. Polycom, Inc.*, C.A. No. 5:19-cv-03918-VKD (N.D. Cal.) involved the '588 patent. Paper 4, 2 (Mandatory Notices). The parties both refer to a single litigation that was originally filed in the Eastern District of Virginia and was then transferred to the Northern District of California in July, 2019.

*C. The '588 Patent*

The '588 patent is entitled “System and Method for Cross Protocol Communication” and issued on August 10, 2010 from an application filed on April 13, 2006. Ex. 1001, codes (22), (45), (54).

The '588 patent is directed to facilitating multimedia communication with multiple communication protocols. Ex. 1001, 2:3–5. The system can handle different types of traffic including forms of Internet communications, such as voice over Internet Protocol (VoIP), and differing types of protocols, such as H.323 and Session Initiation Protocol (SIP), which can accommodate multimedia communication including voice, video, and data communications in real time. *Id.* at 1:18–30. The differing protocols may have different structures and formats and may be incompatible. *Id.* at 1:41–48, 1:58–61. In order to address incompatibility issues, the invention includes a communication controller, which receives a multimedia data stream in a first protocol and converts it to an intermediate protocol. *Id.* at 2:5–10. The multimedia data stream in the intermediate protocol is transmitted to a second communication controller which converts the data

stream to a second protocol that is compatible with the destination communication device. *Id.* at 2:15–18.

Figure 2, reproduced below, is a block diagram illustrating component blocks of communication controller 100. Ex. 1001, 4:20–21.

FIG. 2

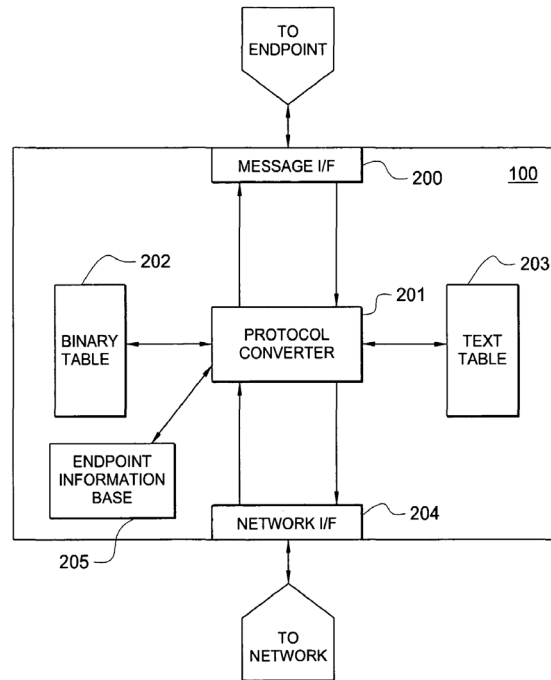
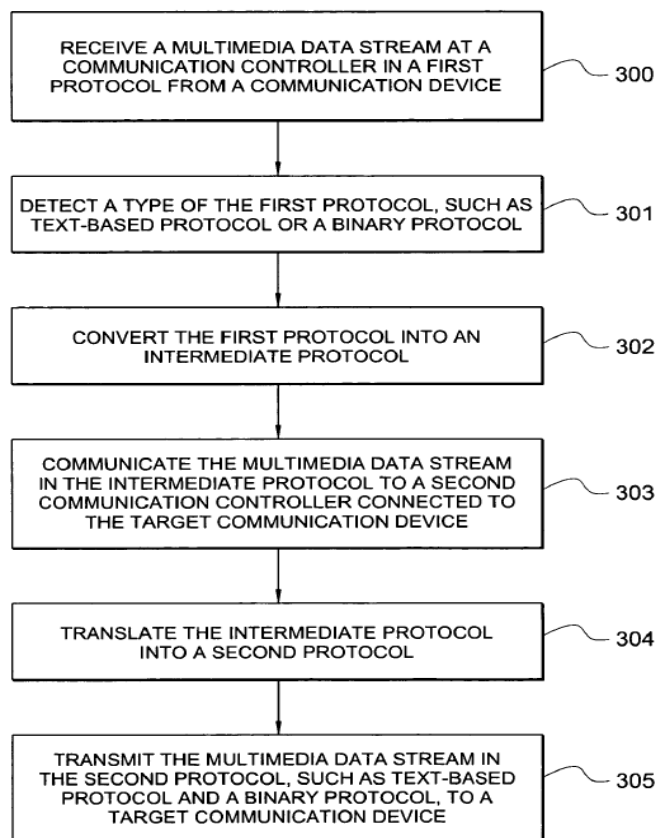

Figure 2, above, shows communication controller 100 receiving data streams from an endpoint at message interface 200, which sends the data stream to protocol converter 201. Ex. 1001, 4:21–27. Protocol converter 201 examines the data stream and determines what protocol the data stream has been configured for and examines the data stream packets to find protocol messages or commands contained within it. *Id.* at 4:27–29. Protocol converter 201 accesses a corresponding table to find the interim protocol message to replace the original message. *Id.* at 4:32–34. More specifically, protocol converter 201 may access binary table 202, when the received

multimedia data stream is in a binary format protocol, or it may access text table 203, when the received multimedia data stream is in a text-based protocol. *Id.* at 4:35–39. As protocol converter 201 assembles the new data stream in the interim protocol, the stream is forwarded to network interface 204 for transmission of the translated data stream onto the network. *Id.* at 4:52–55.

Figure 3, reproduced below, presents an embodiment of a method showing the steps of protocol conversion. Ex. 1001, 5:30–31.

FIG. 3



As shown in Figure 3, above, in step 300, a multimedia data stream is received from a communication device at a communication controller in a first protocol, and at step 301, the type of the first protocol is detected.

IPR2019-01233

Patent 7,773,588 B2

Ex. 1001, 5:30–35. The first protocol is converted into an intermediate protocol in step 302, and the multimedia data stream in the intermediate protocol is communicated, in step 303, to a second communication controller connected to the target communication device. *Id.* at 5:35–39. The intermediate protocol is translated into a second protocol in step 304, and is transmitted to a target communication device at step 305. *Id.* at 5:39–43.

Challenged claims 1, 7, 11, and 18 of the '588 patent are independent. Claims 1 and 7 are reproduced below, with sub-paragraphing added to the limitations for reference purposes.

1. A method for multimedia communication comprising:

- [a] receiving a multimedia data stream at a communication controller in a first protocol from a communication device, wherein the first protocol comprises a signaling protocol;
- [b] detecting a type of said first protocol;
- [c] converting said first protocol into an intermediate protocol;
- [d] translating said intermediate protocol into a second protocol, wherein the second protocol comprises a signaling protocol;
- and
- [e] transmitting said multimedia data stream in said second protocol to a target communication device;
- [f] wherein said first protocol comprises one of a text-based protocol and a binary protocol and wherein said second protocol comprises one of a binary protocol and a text-based protocol.

7. A communication controller in a multimedia communication system, said communication controller comprising:

- [a] a message interface to transceive multimedia data from a communication endpoint in a first protocol, wherein the first

protocol comprises a signaling protocol, and wherein said first protocol is either a text-based protocol or a binary protocol;

[b] a protocol signaler to determine a type of said first protocol;

[c] a first protocol conversion table that contains a plurality of first protocol messages and a plurality of interim protocol messages, wherein said plurality of interim protocol messages correspond to ones of said plurality of first protocol messages;

[d] a protocol conversion utility to convert said first protocol into an interim protocol using said first protocol conversion table; and

[e] a network interface to transceive said multimedia data in said interim protocol to a target communication endpoint.

Ex. 1001, 7:25–41, 8:19–27.

## II. ANALYSIS

### *A. The Parties' Arguments*

In our Decision on Institution, we concluded that the arguments and evidence advanced by Petitioner demonstrated a reasonable likelihood that at least one claim of the '588 patent would have been obvious. Inst. Dec. 19–36. Here, we determine whether Petitioner has established by a preponderance of the evidence that the challenged claims would have been obvious. 35 U.S.C. § 316(e). We previously instructed Patent Owner that “any arguments for patentability not raised in the response may be deemed waived.” Paper 22, 8; *see also* 37 C.F.R. § 42.23(a) (“Any material fact not specifically denied may be considered admitted.”); *In re Nuvasive, Inc.*, 842 F.3d 1376, 1379–82 (Fed. Cir. 2016) (holding patent owner waived an argument addressed in the preliminary response by not raising the same argument in the patent owner response). Additionally, the Board’s Trial Practice Guide states that the Patent Owner Response “should identify all the



involved claims that are believed to be patentable and state the basis for that belief.” Consolidated Trial Practice Guide (“TPG”), 66 (Nov. 2019).<sup>5</sup>

On the record before us, we note that we have reviewed arguments and evidence advanced by Petitioner to support its unpatentability contentions, where Patent Owner chose not to address certain limitations in its Patent Owner Response. In this regard, the record contains persuasive arguments and evidence presented by Petitioner regarding the manner in which the prior art discloses the corresponding limitations of claims 1–23 of the ’588 patent.

*B. Level of Ordinary Skill in the Art*

Petitioner asserts that a person of ordinary skill in the art would have a “a Bachelor’s degree or equivalent in electrical engineering, computer engineering, or similar field, and at least two years’ experience in a relevant field such as telecommunications or multimedia communications.” Pet. 19. In support, Dr. Lavian testifies that the relevant experience could include “experience in designing, implementing, monitoring and maintaining voice over Internet protocol [VoIP] and multimedia networks,” and the person of ordinary skill would therefore have “at least some familiarity with the fundamentals of computer networks and related concepts, including VoIP, multimedia transmissions, protocol conversion, and well-known communication protocols such as SIP, H.323, and TCP/IP.” Ex. 1002 ¶ 18.

In the Decision on Institution, we adopted Petitioner’s proposed skill level, that is, that one of ordinary skill in the art would have a Bachelor’s degree or equivalent in electrical engineering, computer engineering, or similar field, and at least two years of experience in a relevant field such as

---

<sup>5</sup> Available at <https://go.usa.gov/xpvPF>.

IPR2019-01233

Patent 7,773,588 B2

telecommunications or multimedia communications. Inst. Dec. 20. We also agreed with Petitioner that one of ordinary skill would have some familiarity with the design and implementation of VoIP and multimedia networks. *Id.* We did not agree, however, that the qualifications included monitoring and maintaining VoIP and multimedia networks, as Petitioner asserted, and therefore declined to adopt those requirements. *Id.* at 20–21.

In its Response, Patent Owner accepted the qualifications for one of ordinary skill in the art adopted in the Decision on Institution to include “familiarity with the design and implementation of VoIP and multimedia networks,” but further described this requirement to include other requirements:

an understanding of the performance requirements that real-time communication demands, and the constraints that this places on processing and converting a multimedia data stream; and

an understanding regarding the complexity of processing media and signaling and the computational demands this would place on a communication controller.

PO Resp. 16–17. Patent Owner refers to *GPAC*, which identifies the factor of the “type of problems encountered in the art” as a consideration in determining the level of ordinary skill in the art. *Id.* at 17 (citing *In re GPAC*, 57 F.3d 1573, 1579 (Fed. Cir. 1995)).

We have reviewed the relevant technology and claims of the ’588 patent, as well as the technology of the asserted prior art, and we adopt the same qualifications as those adopted in the Decision on Institution because they are commensurate with the relevant technology.

These qualifications are similar to those presented by Petitioner, with the exception that the additional proposed qualifications for monitoring and maintaining VoIP and multimedia networks are not adopted because a

IPR2019-01233

Patent 7,773,588 B2

person of ordinary skill need not have had hands-on experience with the operation of monitoring and maintaining networks. As noted, the previously-adopted qualifications are acceptable to Patent Owner, except that Patent Owner proposes to include some more specific details for the level of qualifications that we decline to add because that specific knowledge, at least at some level, would fall within the knowledge of one with experience in the telecommunications or multimedia communications fields and having familiarity with the design and implementation of VoIP and multimedia networks.

Additionally, we note that in the Decision on Institution, we requested that Patent Owner address what impact, if any, the different levels of proposed qualifications have on the obviousness analysis. Inst. Dec. 21, n.4. Neither Patent Owner nor Petitioner identified any differences in their obviousness analysis due to differences in the qualifications of a person of ordinary skill in the art. *See generally*, PO Resp.; Pet. Reply; PO Sur-Reply.

### *C. Claim Construction*

For cases like this one, where the petition for *inter partes* review was filed after November 13, 2018, the Board interprets claim terms in accordance with the standard used in federal district court in a civil action involving the validity or infringement of a patent. *See Changes to the Claim Construction Standard for Interpreting Claims in Trial Proceedings Before the Patent Trial and Appeal Board*, 83 Fed. Reg. 51,340, 51,340, 51,358 (Oct. 11, 2018) (amending 37 C.F.R. § 42.100(b) effective November 13, 2018) (now codified at 37 C.F.R. § 42.100(b) (2019)). Under the principles set forth by our reviewing court, the “words of a claim ‘are generally given their ordinary and customary meaning,’” as would be understood by a person of ordinary skill in the art in question at the time of the invention.

IPR2019-01233

Patent 7,773,588 B2

*Phillips v. AWH Corp.*, 415 F.3d 1303, 1312 (Fed. Cir. 2005) (en banc) (quoting *Vitronics Corp. v. Conceptronic, Inc.*, 90 F.3d 1576, 1582 (Fed. Cir. 1996)). “In determining the meaning of the disputed claim limitation, we look principally to the intrinsic evidence of record, examining the claim language itself, the written description, and the prosecution history, if in evidence.” *DePuy Spine, Inc. v. Medtronic Sofamor Danek, Inc.*, 469 F.3d 1005, 1014 (Fed. Cir. 2006) (citing *Phillips*, 415 F.3d at 1312–17).

1. “multiple data stream”

The interpretation of “multimedia data stream” is in dispute. In the Patent Owner Response, Patent Owner argues that the primary prior art reference, Ress, teaches only establishing media stream communications, and “does not disclose communicating a multimedia data stream (comprising both signaling and media messages) in a particular protocol.” PO Resp. 18. In its Sur-Reply, Patent Owner asserts that a person of ordinary skill in the art would have understood the term “multimedia data stream” to comprise both signaling and media messages, as this is alleged to be consistent with the language of the claims and the intrinsic record. PO Sur-Reply 3 (citing Ex. 1001, Fig. 1A, Fig. 1B, 1:29–31, 4:20–5:29, 6:11–21, 7:26–30, 7:33–37, 7:59–61). Dr. Jeffay testifies that a person of ordinary skill in the art would have understood that the first and second protocols refer to protocols that govern the format of messages conveying both signaling and media data. Ex. 2001 ¶ 22. Patent Owner argues that Petitioner and its expert, Dr. Lavian, indicate their understanding that both signaling and media data are included in a multimedia data stream. PO Sur-Resp. 3 (citing Ex. 2017, 8–10, 32–33; Ex. 1002 ¶¶ 47, 54; Ex. 2026, 117:21–118:17).

In its Reply, Petitioner argues that Patent Owner’s proposed construction is incorrect. Pet. Reply 1–4. Petitioner asserts that the intrinsic

record does not require that the multimedia data stream being converted has to consist of both signaling and media messages. *Id.* at 3. Petitioner contends that the '588 patent's primary embodiments discuss conversion between H.323 and SIP, and both of these use a different protocol, Real-time Transport Protocol (RTP), to transport media by different paths. *Id.* at 3 (citing Ex. 1001, 1:22–30, 3:25–39; Ex. 1017 ¶¶ 3–4). Petitioner argues that Patent Owner's proposed construction must be rejected because it reads out embodiments of the '588 patent. *Id.*

In supplemental briefing, Petitioner argues that the intrinsic record supports its proposed construction and “[t]he data may be signaling or media content or both.” Pet. Suppl. Br. 1. Petitioner asserts that “the multimedia data stream must contain signaling and may—but need not—contain additional elements.” *Id.* at 1–2 (citing *Genentech, Inc. v. Chiron Corp.*, 112 F.3d 495, 501 (Fed. Cir. 1997) (“‘Comprising’ is a term of art used in claim language which means that the named elements are essential, but other elements may be added.”)). Petitioner also points to Figure 4 of the Specification which shows conversion between a first and intermediate protocol, with the associated disclosure that this process “assembl[es] the intermediate protocol messages to form the multimedia data stream.” *Id.* at 2–3 (citing Ex. 1001, 5:55–58, Fig. 4).

In its Sur-Reply, Patent Owner asserts that Petitioner's arguments rest on the faulty premise that H.323 and SIP are exclusively call signaling protocols that do not have media paths to convert. PO Sur-Reply 5 (citing Ex. 1017 ¶¶ 3–4). Patent Owner argues that the H.323 standard describes how media streams are formatted and exchanged. *Id.* (citing Ex. 1008, 3, 9–11, 18–19). Patent Owner further contends that H.323 and SIP do not limit the transmission of media to RTP, and protocol compatibility issues can

IPR2019-01233

Patent 7,773,588 B2

arise with respect to the transmission of media. *Id.* (citing Ex. 1008, 27; Ex. 1009, 8). Patent Owner contends that Dr. Lavian admits that other protocols, like TCP, UDP, and HTTP, can be used to transport media, and these diverse media protocols are incompatible with each other, “further highlighting the need for the claimed invention to process both signaling and media.” *Id.* at 5–6 (citing Ex. 2041, 9:22–11:4, 14:22–15:2, 15:18–21, 16:13–21). Patent Owner also asserts that H.232 and SIP are a family of protocols that include both a signaling portion and data portion. *See* Ex. 1018, 51:5-20; Ex. 2026, 118:13–17.

In supplemental briefing, Patent Owner asserts that under Petitioner’s proposed construction, “multimedia” means no media. PO Suppl. Br. 1. Patent Owner argues that the plain language of the claim dictates that “multimedia” include media messages. *Id.* Patent Owner refers to Dr. Jeffay’s testimony which states “[m]ultimedia is just – the technical matter is understood as multiple forms of media.” *Id.* at 1–2 (citing Ex. 1018, 31:7–10). Patent Owner argues that “[t]o construe ‘multimedia’ to mean no media improperly rewrites the plain language of the claim term to eliminate the word ‘multimedia.’” *Id.* at 2 (citing *Los Angeles Biomedical Research Inst. at Harbor-UCLA Med. Ctr. v. Eli Lilly & Co.*, 849 F.3d 1049, 1062 (Fed. Cir. 2017)). Patent Owner also argues that a person of ordinary skill in the art would understand the term “multimedia data stream” to include “messages conveying both signaling and media data,” as both Dr. Jeffay and Dr. Lavian have indicated. *Id.* at 2–3 (citing Ex. 2001 ¶ 22; Ex. 2017, 33). Patent Owner also asserts that the ’588 patent Specification supports its proposed construction by disclosing that “[t]he two endpoints and systems speak different languages and, thus, cannot understand the messaging *and* data being transmitted by the other.” *Id.* at 3 (citing Ex. 1001, 1:61–64).

Patent Owner argues that in the '588 patent, the media messages must be included in the multimedia data stream received by the communication controller because otherwise, the actual content of conversations would never be exchanged in embodiments. *Id.* at 4 (citing Ex. 1001, Figs. 1A, 1B, 2). Patent Owner argues that H.323 is a suite of protocols that includes both signaling and media protocols, and SIP is a family of protocols that conveys both signaling and media messages. *Id.* at 4–5 (citing Ex. 2001 ¶ 22; Ex. 2009 ¶ 73; Ex. 1018, 37:6–9, 49:10–20, 38:15–17, 51:5–20; Ex. 1008, 10–12). Patent Owner asserts that Dr. Lavian agreed that transmission of a multimedia communication using SIP conveys both signaling and media messages. *Id.* at 5 (citing Ex. 2026, 118:13–17).

In its Response to the supplemental briefing, Petitioner asserts that Patent Owner selectively cites to Dr. Lavian's district court declaration addressing a different claim construction issue, and Dr. Lavian also explained in that declaration that the SIP and H.323 standards carry signaling, while the content is carried by RTP. Pet. Suppl. Resp. Br. 2 (citing Ex. 2017, 32–33). Petitioner disputes Patent Owner's contention that Figures 1A, 1B, and 2 of the '588 patent support its construction because Figure 2's controller is converting messages (i.e., signals), not media content, and Figures 1A and 1B are shown converting between "text" and "binary" protocols. *Id.* Petitioner also asserts that Patent Owner has never refuted Petitioner's point that both SIP and H.323 typically send media content over the RTP protocol on a separate data stream. *Id.* at 2–3.

In its Response to supplemental briefing, Patent Owner argues that Petitioner is asserting that "multimedia" does not modify "data stream," but rather modifies the word "protocol" found later in limitation [a], which distorts the plain language of the claim. PO Suppl. Resp. Br. 1. Patent

Owner argues that “[i]f ‘multimedia’ was intended to modify ‘protocol,’ the claim term should have been drafted as ‘receiving a data stream at a communication controller in a first *multimedia* protocol.’” *Id.* Patent Owner also contends that Petitioner’s proposed construction is predicated upon its assertion that the word “message” only refers to “signaling,” but “message” is simply a generic reference for a transmission structure comprising a header and payload. *Id.* at 1–2 (citing Ex. 2009 ¶ 56). Patent Owner asserts that the communication controller in the ’588 patent receives both signaling and media messages, with one embodiment disclosing that the protocol converter inside the communication controller packages “the payload or data [the media] from the original data stream along with the message or command in the interim protocol.” *Id.* at 2 (citing Ex. 1001, 4:47–51, Fig. 2). Patent Owner contends that Petitioner’s assertion there is no media content received at initiation of a communication is merely attorney argument, and further that the ’588 patent does not describe H.323 and SIP as only signaling protocols. *Id.* at 3 (citing Ex. 1001, 1:31–34).

In accordance with *Phillips*, “the claims themselves provide substantial guidance as to the meaning of particular claim terms.” *Phillips*, 415 F.3d at 1314. Limitations of claim 1 recite: “*receiving a multimedia data stream at a communication controller in a first protocol from a communication device, wherein the first protocol comprises a signaling protocol,*” and “*translating said intermediate protocol into a second protocol, wherein the second protocol comprises a signaling protocol.*” Ex. 1001, 7:27–30, 7:33–35 (emphasis added). Thus, according to the claim language itself, a “multimedia data stream” in the respective protocols is recited to comprise a signaling protocol.



Turning to the Specification, although it does not have an explicit definition of a “multimedia data stream,” it refers to protocols, specifically H.323 and SIP, for use in multimedia communications:

Two examples of such protocols that have been defined for handling the administration of VoIP, and its natural extension to multimedia communication are H.323 from the International Telecommunication Union-Telecommunication Standardization Sector (ITU-T) and the Session Initiation Protocol (SIP) from the Internet Engineering Task Force (IETF). Both H.323 and SIP typically allow for multimedia communication including voice, video, and data communications in real-time.

Ex. 1001, 1:22–30. Additionally, the Specification describes the use of SIP and H.323 in the invention:

Endpoints 101 and 107 each use a text-based communication protocol, such as SIP, while endpoints 102 and 106 each use a binary communication protocol, such as H.323. SIP and H.323 are merely specific examples of text-based and binary protocols. Other protocols may be used as well.

Ex. 1001, 3:25–29. Dr. Lavian refers to the IETF’s “SIP-H.323 Interworking” document, dated July 13, 2001, as support for his testimony that SIP and H.323 are signaling protocols. *See* Ex. 1017 ¶ 3; Ex. 1010. Consistent with his testimony, the IETF document states that

[t]he primary objective of the SIP-H.323 Interworking function (IWF) is to provide protocol conversion between SIP and H.323 protocol. Both of these protocols use similar formats (e.g. RTP) to transfer media (audio/video/data) over the Packet Network. It is, therefore, required to perform the mapping between SIP and H.323 signaling messages only to achieve the interworking between the two protocols. The objective is to transmit media end-to-end directly between the two end systems in H.323 and SIP networks.

Ex. 1010, 3–4. Dr. Lavian additionally testifies that SIP is defined in RFC 3261, the official Internet signaling protocol for IP networks, as purely a

signaling protocol “that can be used with other IETF protocols to build a complete multimedia architecture” and “[t]ypically, these architectures will include protocols such as the Realtime Transport Protocol (RTP).” Ex. 1002 ¶ 53 (citing Ex. 1009, 9).

The Specification discloses the use of SIP in the embodiments of the ’588 patent. We credit Dr. Lavian’s testimony that one of ordinary skill in the art would consider SIP to be a signaling protocol because this testimony is supported by other prior art, as discussed above. For instance, RFC 3261 discloses that “SIP is an application-layer control protocol that can establish, modify, and terminate multimedia sessions (conferences) such as Internet telephony calls,” which are signaling functions, and the data itself is transported in RTP. *See* Ex. 1009, 9.

Dr. Jeffay also concurs with Dr. Lavian’s understanding of SIP, testifying that

SIP is only used to establish sessions. It does not carry the actual media for the session. As such, SIP is considered a “signaling” protocol as it generates the “signals” (messages) to set up and manage a call . . . RTP, or Real-Time Transport Protocol, is an application layer protocol for actually carrying the media of a multimedia communication session.

Ex. 2009 ¶¶ 75–76. The evidence of record supports that the Specification of the ’588 patent discloses embodiments that use SIP and H.323. Patent Owner’s references to the ’588 patent do not refute Petitioner’s arguments that these protocols are used. *See* Ex. 1001, Fig. 1A, Fig. 1B, 1:29–31, 4:20–5:29, 6:11–21, 7:26–30, 7:33–37, 7:59–61. As discussed, the evidence further supports that one of ordinary skill in the art would understand SIP to be a signaling protocol.

“[T]here is a strong presumption against a claim construction that excludes a disclosed embodiment.” *See In re Katz Interactive Call Processing Patent Litig.*, 639 F.3d 1303, 1324 (Fed. Cir. 2011). Thus, because the Specification discloses the use of signaling protocols only, such as by the use of SIP, in its multimedia communications in embodiments, it supports a claim construction for the term “multimedia data stream” that includes signaling messages only. This interpretation is consistent with the claim language itself, where the “multimedia data stream” protocols are recited to comprise a signaling protocol.

Accordingly, we find that the evidence of record supports Petitioner’s construction that the recited “multimedia data stream” does not have to consist of both signaling and media messages, and may be a signaling message only.

Patent Owner also asserts that Petitioner did not propose any claim constructions in the Petition, relying on the ordinary and customary meaning of terms, and in its Reply, Petitioner now proposes a construction of “multimedia data stream” that is inconsistent with the ordinary meaning of the term. PO Sur-Reply 1–2. As such, Patent Owner asserts that Petitioner’s belated argument must be rejected as a matter of law. *Id.* at 2. We are not persuaded by Patent Owner’s argument on this issue because Petitioner’s arguments respond to issues on the merits of Ressa’s teachings first raised in Patent Owner’s Response, which could not have been reasonably anticipated when the Petition was filed. *See TPG*, 73–75.

## 2. Other Claim Terms

We determine that it is not necessary to provide an express interpretation of any other claim terms. *See Nidec Motor Corp. v. Zhongshan Broad Ocean Motor Co.*, 868 F.3d 1013, 1017 (Fed. Cir. 2017);

IPR2019-01233

Patent 7,773,588 B2

*Vivid Techs., Inc. v. Am. Sci. & Eng'g, Inc.*, 200 F.3d 795, 803 (Fed. Cir. 1999) (“[O]nly those terms need be construed that are in controversy, and only to the extent necessary to resolve the controversy.”).

*D. Alleged Obviousness of Claims 1–23 Over Ress*

In the Petition, Petitioner contends that claims 1–23 are rendered obvious by Ress. Pet. 21–56. To support its contentions, Petitioner provides explanations as to how Ress teaches each claim limitation. *Id.* Petitioner also relies upon the Lavian Declarations (Ex. 1002; Ex. 1017) to support its positions. Patent Owner argues that the prior art asserted fails to teach or suggest some of the claim limitations and the rationale to combine the references is insufficient, with Dr. Jeffay providing supporting testimony. *See generally* PO Resp.; Ex. 2001; Ex. 2009.

We begin our discussion with a brief summary of Ress and then address the evidence and arguments presented.

*1. Ress (Ex. 1004)*

Ress is directed to a method and apparatus for interworking between internet protocol (IP) telephony protocols. Ex. 1004, 1:13–17. The system includes a call server that has a first protocol agent for communicating with a first protocol device according to a first protocol and a second protocol agent that communicates with a second protocol device according to a second protocol. *Id.* at 3:11–16. An interworking agent provides functions usable by the first and second protocol agents to communicate using a third protocol. *Id.* at 3:16–18. Figure 3, reproduced below, depicts a block diagram illustrating media gateway controller (MCG) and gatekeeper (GK) functions implemented within a call server according to an embodiment of the invention. *Id.* at 3:37–40.

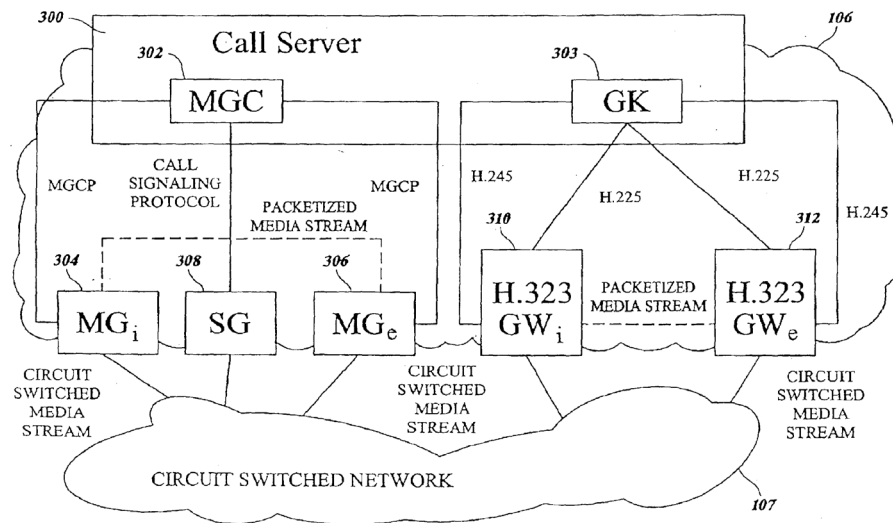

FIG. 3

Figure 3, above, depicts an embodiment of the invention with call server 300, which includes MGC function 302 and GK function 303. Ex. 1004, 4:43–46.

The interworking agent provides functions usable by the first and second protocol's agents to communicate using a third protocol, where the third protocol provides a superset of the functions provided by the first and second protocols. Ex. 1004, 3:16–20. Figure 5, reproduced below, illustrates a call server that includes a plurality of interworking agents. *Id.* at 3:41–43.

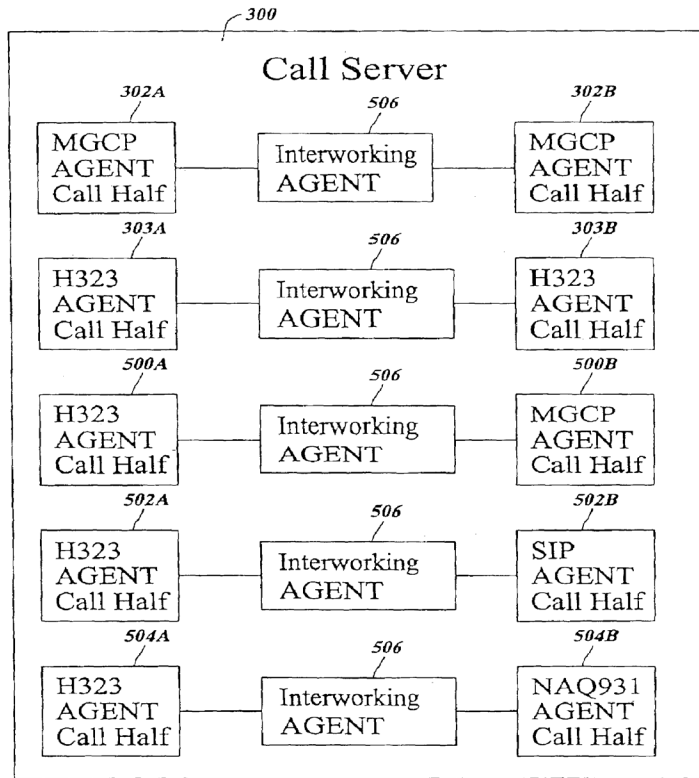

FIG. 5

As illustrated in Figure 5, above, interworking agent 506 provides functions usable by different protocol agents to provide interworking between the protocol agents. Ex. 1004, 5:35–38.

The invention provides for a mechanism provided by agent interworking protocols for implementing media management and exchange by using connection information parameters (CIP) depicted in Figure 8, reproduced below. Ex. 1004, 8:8–12.

Connection Information Parameter	
Field	Example Values
800 Media Type	Audio, Video, Data 802
804 Channel ID	12345 806
808 Channel Operation	No action, open, close, modify, mode change, redirect, direct, send capabilities 810
812 Current Media Description	G.711@2 frames/packet 814
816 Media Capabilities	G.711, G.729, RTP address, payload size, media specific information 818

FIG. 8

Figure 8, above, is a table showing example fields and field values for the connection information parameter according to an embodiment of the invention. Ex. 1004, 8:16–18. Current media description field 812 stores current media description value 814 that indicates the description of the current media stream. *Id.* at 8:52–54. Media capabilities field 816 includes media capabilities value or values 818 that allow an entity to exchange its media capabilities with another entity. *Id.* at 8:56–58. In the example depicted in Figure 8, the media capabilities field includes a list of supported formats, such as G.711 or G.729. *Id.* at 8:58–60.

## 2. Analysis

A patent claim is unpatentable under 35 U.S.C. § 103(a) if the differences between the claimed subject matter and the prior art are such that the subject matter, as a whole, would have been obvious at the time the invention was made to a person having ordinary skill in the art to which said subject matter pertains. *KSR Int'l Co. v. Teleflex Inc.*, 550 U.S. 398, 406 (2007). The question of obviousness is resolved on the basis of underlying

factual determinations including: (1) the scope and content of the prior art; (2) any differences between the claimed subject matter and the prior art; (3) the level of ordinary skill in the art; and (4) objective evidence of nonobviousness. *Graham v. John Deere Co.*, 383 U.S. 1, 17–18 (1966).

*a. Independent claim 1*

*i. Preamble and Limitation [a]*

Petitioner asserts that Ress teaches a method for multimedia communication, as recited in the preamble of claim 1. Pet. 22. Petitioner relies upon Ress’s disclosure that it is directed to a method and apparatus for interworking between IP telephony protocols. *Id.* (citing Ex. 1004, 1:15–17).

We have reviewed Petitioner’s arguments and evidence and determine that Petitioner has provided sufficient evidence that Ress teaches the preamble of claim 1.<sup>6</sup>

Petitioner contends that Ress teaches limitation [a] by its disclosure of the use of protocols for establishing “media stream communications, such as voice, data, video, or combinations thereof, over an IP network,” with the multimedia data streams received at various communication controllers such as gateways, terminals and multipoint control units. Pet. 22 (citing Ex. 1004, 1:20–24, 1:58–62, Figs. 3, 4). Petitioner asserts that Ress discloses a call server that “includes a first protocol agent for communicating with a first protocol device according to a first protocol,” and that the first protocol can be a signaling protocol, such as H.323. *Id.* at 23 (citing Ex. 1004, code (57), 5:15–61, Figs. 5, 6). Petitioner further contends that data streams in

---

<sup>6</sup> We make no specific determination as to whether the preamble of claim 1 is limiting.



IPR2019-01233

Patent 7,773,588 B2

Ress are received from communication devices, such as end user devices with gateways. *Id.* at 24 (citing Ex. 1004, 1:46–48, 2:6–9, 18:7–14).

Patent Owner argues that Ress does not teach or suggest “receiving a multimedia data stream . . . in a first protocol” because a person of ordinary skill in the art would have understood that the first protocol format for the multimedia data stream would include both signaling and media messages. PO Resp. 18 (citing Ex. 2016 ¶¶ 20–21). Dr. Jeffay contends that Ress discloses specific gateways and their use of control signaling to establish media streams, but “is otherwise silent on their use to actually receive a multimedia data stream.” Ex. 2009 ¶ 93.

Patent Owner also asserts that Ress fails to teach receiving the multimedia data stream at the claimed “communication controller” from the claimed “communication device.” PO Resp. 19. Patent Owner argues that Ress “is focused on the manner in which these various network elements work to *establish* a media stream over the packet network.” *Id.* Patent Owner refers to annotated Figure 3, reproduced below, in support of its argument. *Id.* at 19–20.

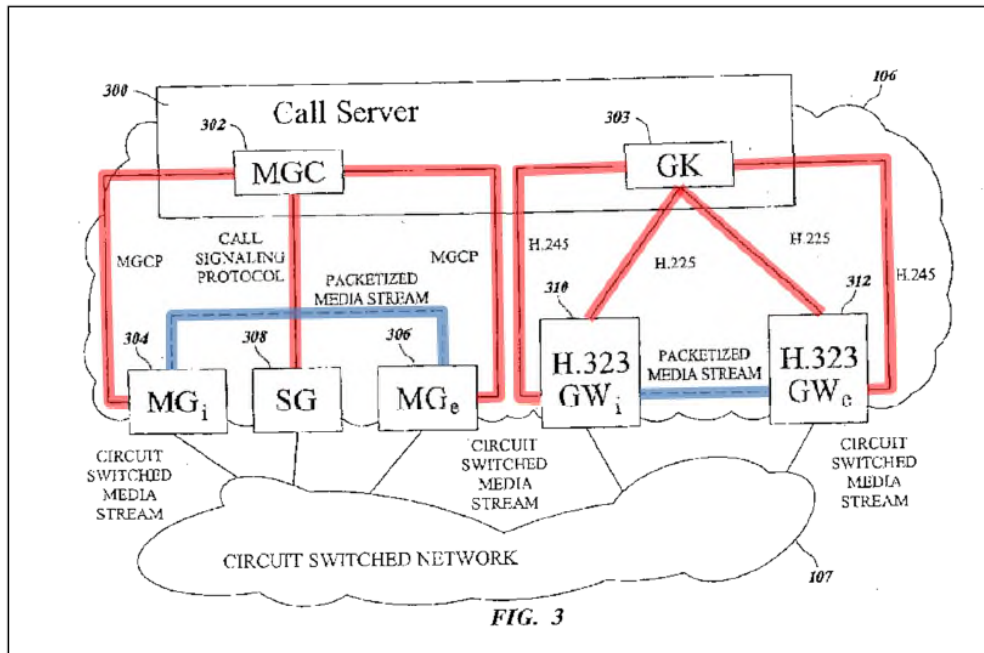

Annotated Figure 3 of *Ress*, reproduced above, is a block diagram illustrating media gateway controller and gatekeeper functions implemented within a call server. Ex. 1004, 3:37–40. Patent Owner, referring to annotated Figure 3, argues that “*Ress* illustrates a ‘packetized media stream’ (in blue) communicated between gateways is not associated with the signaling messages (in red) communicated to the call server,” so *Ress* fails to disclose a first protocol for communicating the packetized media stream. PO Resp. 19.

Patent Owner’s arguments are based upon its proposed construction of the term “multimedia data stream,” which we have not adopted. Instead, as discussed above, we have interpreted the claimed “multimedia data stream” so that it may consist of signaling messages only. Under that construction, we determine that Petitioner’s assertion that *Ress*’s receipt of messages in a first signaling protocol by the call server sufficiently teaches limitation 1 [a].

*ii. Limitation [b]*

Petitioner contends that limitation [b] of claim 1, “detecting the type of said first protocol,” is taught by Ress’s disclosure that “[e]ach of the agent protocols to be interworked provide some means by which a telephony device can make known the media capabilities that it supports.” Pet. 24 (citing Ex. 1004, 6:57–60). Petitioner argues that “[i]n order to convert the message from a first protocol to an intermediate protocol, the inter[ ]working agents of Ress first detect the type of first protocol being used by the device.” *Id.* at 24–25 (citing Ex. 1004, 5:33–35 (“Interworking agents can also identify AIP [agent interworking protocol] message types”)). Petitioner refers to the table of Ress’s Figure 8 that contains exemplary fields and field values for the connection information parameter (CIP). *Id.* (citing Ex. 1004, 8:16–18). Petitioner contends that the current media value indicates the protocol that the media stream is using, and based on the type of protocol detected, the interworking agent converts messages to the protocol independent agent interworking protocol. *Id.* at 25 (citing Ex. 1004, 8:8–18, 8:52–67, Fig. 8). Petitioner also asserts that Figures 9(a) and 9(b) of Ress illustrate the detecting step because the system “determines the message type.” *Id.* at 26.

Petitioner directs us to the steps of Figures 9(a) and 9(b) of Ress, reproduced below with Petitioner’s annotations. Pet. Reply 7–9.

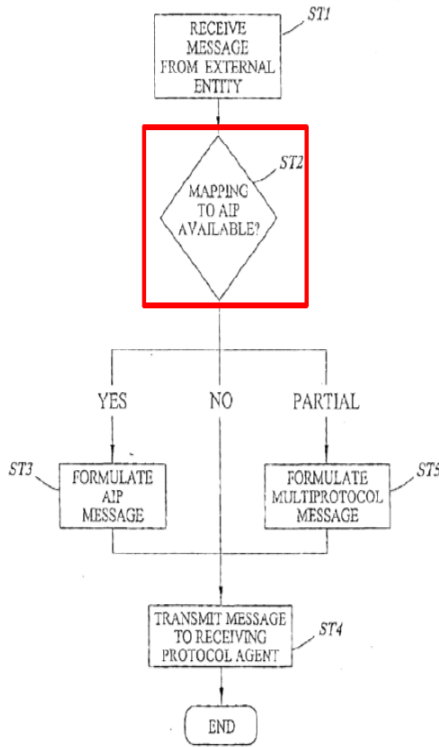
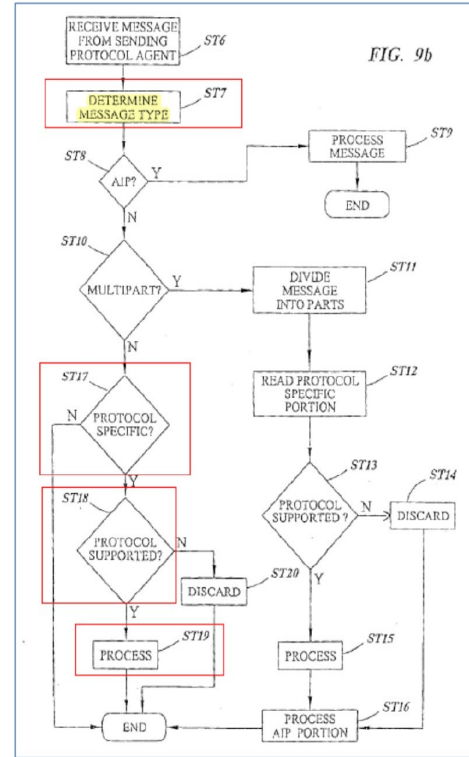

Fig. 9(a)



Annotated Figures 9(a) and 9(b), reproduced above, are flow charts illustrating messaging in embodiments of Ress. *See* Ex. 1004, 3:59–61. Petitioner refers to step ST2 of Figure 9(a), asserting that Ress checks a type of protocol to determine whether the AIP has a mapping available. *Pet. Reply* 7 (citing Ex. 1004, 9:58–60; Ex. 1017 ¶¶ 18–19). Petitioner also refers to step ST7 of Figure 9(a), asserting that determining the message type requires detecting protocol type and also that in order to determine whether a message is supported (step ST18), the protocol must be detected to make that determination. *Id.* at 8 (citing 1004, 10:25–41; Ex. 1017 ¶¶ 20–21).

Dr. Lavian testifies that in Figure 9(a) of Ress, checking if a mapping of AIP is available requires detecting the type of protocol and checking if the detected type is supported. Ex. 1017 ¶ 19. Dr. Lavian also testifies that “to

IPR2019-01233

Patent 7,773,588 B2

detect media capabilities for a particular device in Ress, the MGC must also detect the agent protocol corresponding to that device.” *Id.* ¶ 17. Dr. Lavian testifies that in order “to determine whether an AIP mapping is available between two protocols . . . Ress’ call server must know which protocols it is converting.” *Id.* Dr. Lavian refers to Ress’s Figure 5, testifying that the interworking agent is the glue between the protocols, and “Ress’ call server must know which protocols it is converting.” *Id.*

Patent Owner argues that Ress’s disclosure that “[e]ach of the agent protocols to be interworked provide . . . means [to] make known the media capabilities that it supports,” upon which Petitioner relies, merely acknowledges that the agent protocols provide a mechanism to “make known” the media capabilities (e.g., audio or video codecs) that the device supports. PO Resp. 21 (citing Ex. 2009 ¶¶ 101–112; Ex. 1004, 6:55–7:32). Patent Owner asserts that Petitioner’s argument based on the interworking agent’s ability to identify AIP message types and determine whether a mapping to the AIP is available conflates the type of protocol with the type of message within a protocol or the type of media format supported by the protocol. *Id.* (citing Pet. 25; Ex. 1002 ¶ 96; Ex. 2009 ¶¶ 101–112). Patent Owner contends that a person of ordinary skill in the art would understand that neither the interworking agent’s ability to identify or determine a type of message in the AIP, nor the sending protocol’s ability to determine whether a mapping is available to the AIP, say anything about the interworking agent’s ability to detect the actual protocol itself. *Id.* at 21–22 (citing Ex. 2009 ¶¶ 101–112).

Patent Owner additionally asserts that the Petition’s reference to Ress’s CIP does not teach detection. PO Resp. 22. Patent Owner argues that the CIP represents the data structure provided within the AIP, but these

field values do not indicate a type of said first protocol because the AIP is intended to be a protocol independent format. *Id.* (citing Ex. 1004, 6:23–25, 8:9–12). Patent Owner also asserts that Figures 9(a) and 9(b) do not teach detecting because, similar to CIP field values, they merely teach the ability to determine whether a mapping to an AIP message is available (ST2) or determine an AIP message type (ST7). *Id.* (citing Pet. 26; Ex. 1002 ¶ 97; Ex. 2009 ¶¶ 101–112). Patent Owner argues that “ST1 of Fig. 9(a) confirms that the sending protocol agent already knows the protocol in use, as it directly receives the message.” *Id.*

Having considered both parties’ arguments, we are persuaded by Petitioner’s showing that Ress suggests limitation [b], despite Patent Owner’s arguments to the contrary. Petitioner argues, and we agree, that Patent Owner’s argument that Ress does not disclose protocol detection “amounts to arguing that Ress converts between various protocols without knowing which protocols are being converted.” Pet. Reply 6. The goal of Ress’s invention is interworking between different telephony protocols. *See* Ex. 1004, code (57). We credit Dr. Lavian’s testimony that, in order to perform AIP mapping and protocol conversion, the protocol must be detected. *See* Ex. 1001 ¶ 98; Ex. 1017 ¶ 19. Although Ress does not disclose the details of how the protocol detection is performed by the call server, as Dr. Lavian testifies “[i]f a packet type is not detected, it is impossible to process.”<sup>7</sup> *Id.* ¶ 16. We underscore that Petitioner’s challenge is based on obviousness, which does not require that the reference explicitly disclose what is claimed—rather, the reference need only suggest the

---

<sup>7</sup> Petitioner notes that the ’588 patent does not disclose how its detection is done. Tr. 47:1–3. Petitioner also confirms that its position is that the call server of Ress is doing the detection as claimed. *Id.* at 15:20–21.

teaching to one skilled in the art. *See In re Mouttet*, 686 F.3d 1322, 1333 (Fed. Cir. 2012) (“[T]he test for obviousness is what the combined teachings of the references would have suggested to those having ordinary skill in the art.”).

For issues relating to Figures 9(a) and 9(b) of Ress, Patent Owner’s arguments are keyed to the assertion that Ress’s agents will receive only messages in certain protocols, so that the agent need not detect any protocols. PO Resp. 22–23; Ex. 2009 ¶¶ 107–108. For instance, Dr. Jeffay testifies that the first step (ST1) in Figure 9(a) labelled “Receive Message from External Entity” indicates to a person of ordinary skill in the art “that the Ress protocol agent already knows the protocol in use and simply (and directly) receives the message as the first step already knows the protocol in use and simply (and directly) receives the message as the first step.” Ex. 2009 ¶ 107. Dr. Jeffay further testifies that “Ress teaches that protocol detection is not necessary because messages in a given protocol will be received by an agent designed to handle that protocol.” *Id.* ¶ 108. Although agents within the call server may be specific to protocols, this does not detract from the evidence, including Dr. Lavian’s testimony, that first protocol detection would be required in Ress. Notably, Patent Owner does not address how Ress could teach advanced knowledge of the type of protocol (PO Resp. 23), if there is no protocol detection performed by Ress in the first place. Accordingly, we are not persuaded by these Patent Owner arguments relating to limitation 1[b].

Additionally, Petitioner asserts that it would have been obvious to a person of ordinary skill in the art to implement the system of Ress to detect the type of the first protocol with a reasonable expectation of success in doing so. Pet. 26–27. Petitioner contends that a person of ordinary skill in

the art would have understood that the ability to convert between protocols requires the ability to detect what type of protocol is being converted in order to understand how to convert that protocol. *Id.* (citing Ex. 1002 ¶¶ 66–73, 98). Dr. Lavian testifies that only a small amount of code is required to analyze the headers of incoming packets to determine protocol and this is implicit in the IETF standards and was well-known to a person of ordinary skill in the art at the time. Ex. 1002 ¶ 98. Patent Owner argues that “detecting” would have not been obvious in *Ress* because “conversion can readily occur without detection where the type of protocol is known in advance.” PO Resp. 23. We do not find Patent Owner’s argument to be persuasive because there is no explanation of where the advanced determination of protocol would be done. Accordingly, in addition to our determination that *Ress* suggests the detecting step to one of ordinary skill in the art, we also find that Petitioner’s arguments on this basis, that is, that it would have been obvious to a person of ordinary skill in the art to implement the system of *Ress* to detect the type of the first protocol, are sufficient.

Thus, we determine that Petitioner’s evidence and argument sufficiently demonstrate that *Ress* teaches or suggests limitation 1[b].

*iii. Limitation [c]*

Petitioner asserts that *Ress* teaches an interworking agent that provides functions usable by the first and second protocol agents to communicate with each other according to a third protocol, with the third protocol equivalent to the claimed “intermediate protocol.” Pet. 27 (citing Ex. 1004, code (57)). Petitioner contends that *Ress* teaches that interworking agents receive messages in various protocols and converts



them into a third protocol or AIP. *Id.* at 27–28 (citing Ex. 1004, 5:29–33, 6:12–19, 6:22–37, Figs. 6, 7).

Patent Owner argues that Ress fails to teach this limitation because the limitation requires conversion of the entire multimedia data stream, that is, both signaling and media messages. PO Resp. 24–25. We do not find this argument persuasive for the reasons discussed above for limitation 1[a].

We have reviewed Petitioner’s arguments and evidence for this claim limitation and are persuaded that Petitioner has sufficiently shown that Ress teaches limitation [c] of claim 1.

*iv. Limitation [d]*

Petitioner asserts that Ress teaches limitation [d] by its disclosure of a receiving protocol agent that receives a message from the sending protocol agent using the independent protocol (IAP), where the receiving protocol agent converts the intermediate IAP protocol into a second protocol (such as H.323 or SIP). Pet. 29 (citing Ex. 1004, code (57), 5:14–61, 10:10–41, Figs. 5, 6; 9(b)).

Patent Owner argues that Ress fails to teach this limitation because it “fails to disclose translating both the signaling and media messages of a multimedia data stream.” PO Resp. 25. We do not find this argument persuasive for the reasons discussed above for limitation 1[a].

We have reviewed Petitioner’s arguments and evidence for this claim limitation and are persuaded that Petitioner has sufficiently shown that Ress teaches limitation [d] of claim 1.

*v. Limitation [e]*

Petitioner asserts that Ress teaches limitation 1[e] by its disclosure of transmissions to target communication devices in the form of end user devices via gateways. Pet. 29–30. For instance, Ress discloses that with

regard to Figure 2, “a first gateway 200 can be associated with a calling end user device and a second gateway 202 can be associated with a called end user device for a given media communication,” with SIP sessions that include “internet multimedia conferences, internet telephone calls, and multimedia distribution.” *Id.* (citing Ex. 1004, 1:46–48, 1:64–65, 2:6–9, 2:30–42, 3:5–10, 18:7–14, Fig. 2).

Patent Owner argues that Ress fails to disclose transmitting a multimedia data stream because it does not disclose receiving a multimedia data stream. PO Resp. 26. We do not find this argument persuasive for the reasons discussed above for limitation 1[a].

We have reviewed Petitioner’s arguments and evidence for this claim limitation and are persuaded that Petitioner has sufficiently shown that Ress teaches limitation [e] of claim 1.

*vi. Limitation [f]*

Petitioner contends that Ress teaches limitation [f] by its disclosure of first and second protocols that may be H.323 or SIP, for example. Pet. 30 (citing Ex. 1004, 5:15–61, 7:13–32, Figs. 5, 6). Petitioner asserts that the ’588 patent discloses that H.323 is an example of a binary format protocol and SIP is an example of a text-based protocol. *Id.* (citing Ex. 1001, 1:43–44, 1:46–48). Dr. Lavian provides supporting testimony on the types of protocols disclosed in Ress. Ex. 1002 ¶¶ 79, 103.

Patent Owner presents no arguments related to limitation 1[f].

We have reviewed Petitioner’s arguments and evidence for this claim limitation and are persuaded that Petitioner has sufficiently shown that Ress teaches limitation [f] of claim 1.

*vii. Conclusion*

We have considered Patent Owner’s arguments concerning objective indicia of nonobviousness, discussed below. PO Resp. 49–55. For the reasons discussed, we find that Patent Owner’s evidence purportedly showing long-felt need, unexpected results, and industry praise, does not outweigh Petitioner’s evidence concerning the obviousness of claim 1. On the full record, Petitioner has established by a preponderance of the evidence that claim 1 would have been obvious over Ress.

*c. Independent Claim 7*

Independent claim 7 is an apparatus claim with limitations that parallel most of those in claim 1. *Compare* Ex. 1001, 7:26–41, *with id.* at 8:19–37. Petitioner contends that the “communication controller” in the claim 7 preamble is equivalent to Ress’s call server, which “performs call signaling functions, such as translations and media capabilities exchange, on behalf of an end user device, gateway, or other entity.” Pet. 22 (citing Ex. 1004, 3:8–10). Claim 7 also recites “a message interface to transceive multimedia data from a communication endpoint in a first protocol,” and Petitioner contends that the “message interface” functionality is performed by Ress’s call server. Pet. 43–44 (citing Ex. 1004, 9:46–49). Petitioner asserts that Ress discloses that the call server contains call halves that serve to transceive multimedia data from a communication endpoint using multimedia protocols such as H.323 and SIP. *Id.* at 43–44. Petitioner contends that the “protocol signaler” recited in claim 7 is performed by Ress’s call server. *Id.* at 44. Petitioner asserts that the connection information parameter data structure table in Figure 8 of Ress corresponds to the claimed “first protocol conversion table.” *Id.* at 44–45. Petitioner contends that the claimed “protocol conversion utility” is performed by the

interworking agents of the call server of Ress. *Id.* at 45. For limitation 7[e], the Petition contends that the claimed “network interface” is the endpoints in Ress, such as gateways and terminals, that transceive multimedia data in an interim protocol to other endpoints. *Id.* at 45–46 (citing Ex. 1004, Figs. 1, 2, 7). Petitioner also asserts that Ress discloses limitation 7[e] for the reasons disclosed in limitation 1[e]. *Id.* at 45.

For the preamble and limitation 7[a], Patent Owner argues that Petitioner fails to provide any facts to support its contentions that a person of ordinary skill in the art would understand that Figures 5, 9(a) and 9(b) of Ress disclose the claimed message interface. PO Resp. 34–35. Patent Owner also argues that in Ress packetized media streams never reach the call server and do not teach “tranceiv[ing] multimedia data.” *Id.* at 35–36.

For the preamble and limitation 7[a] of claim 7, we have reviewed the arguments and evidence and are persuaded that Petitioner has sufficiently shown that Ress teaches the preamble and limitation 1[a] of claim 7.<sup>8</sup> We do not find Patent Owner’s argument regarding lack of support in the Petition to be persuasive because, as Petitioner explains, the Petition cites to Figures 9(a) and 9(b) of Ress, showing processing by the sending and receiving protocol agents to “receive message from external entity” and “transmit message to receiving protocol agent,” which Petitioner asserts discloses the claimed message interface that transceives multimedia data. Pet. Reply 16 (citing Pet. 43–44; Ex. 1004, 9:46–56, Figs. 9(a), 9(b)). We also do not find convincing Patent Owner’s argument that packetized media streams never reach the call server and, thus, Ress fails to disclose

---

<sup>8</sup> We make no specific determination as to whether the preamble of claim 7 is limiting.

“tranceiv[ing] multimedia data,” because it is based on Patent Owner’s proposed construction of the term “multimedia data stream,” which we have not adopted for the reasons discussed above.

For limitations 7[b]–7[d], we have reviewed the arguments and evidence and are persuaded that Petitioner has sufficiently shown that Ressa teaches these limitations. For limitations 7[b] and 7[d], Patent Owner argues that Ressa does not disclose these limitations for the reasons presented for limitations 1[a]–1[c]. PO Resp. 37. We do not find these arguments persuasive for the reasons discussed for claim 1.

Patent Owner asserts that Petitioner fails to demonstrate that Ressa teaches limitation 7[e]. PO Resp. 37–38. Patent Owner argues that Ressa does not contain a “communication controller” having a “network interface.” *Id.* Patent Owner argues that limitation 1[e] has a notably distinct scope from limitation 7[e]. *Id.* (citing Ex. 2009 ¶¶ 153–154). Dr. Jeffay testifies that Petitioner’s contentions under limitation 1[e] do not apply to limitation 7[e] because in Ressa gateways and terminals do not receive messages in the interim AIP protocol. Ex. 2009 ¶ 153. Dr. Jeffay testifies that the AIP protocol is only used for communications between protocol agents in the call server in Ressa. *Id.*

In Reply, Petitioner asserts that limitation 7[e] claims a distributed system similar to Ressa’s Figure 6 “where the interim protocol is transmitted between different endpoints, each containing its own interworking agent and call agent.” Pet. Reply 17 (citing Ex. 1004, 5:45–47 (“call server 300 . . . is divided into call servers 300A, 300B, and 300C, which can execute on the same machine or different machines”); Ex. 1017 ¶ 33). Petitioner argues that “[t]he different machines running the call server can be endpoints such

as gateways, terminals, MCUs, etc., as discussed in the Petition.” *Id.* at 18 (citing Pet. 29–30, 45–46; Ex. 1017 ¶¶ 33–34).

Figure 6 of Ress, reproduced below, “is a block diagram illustrating protocol agents implementing originating and terminating call half functions executing on different machines wherein an interworking agent is associated with each protocol agent.” Ex. 1004, 3:48–50.

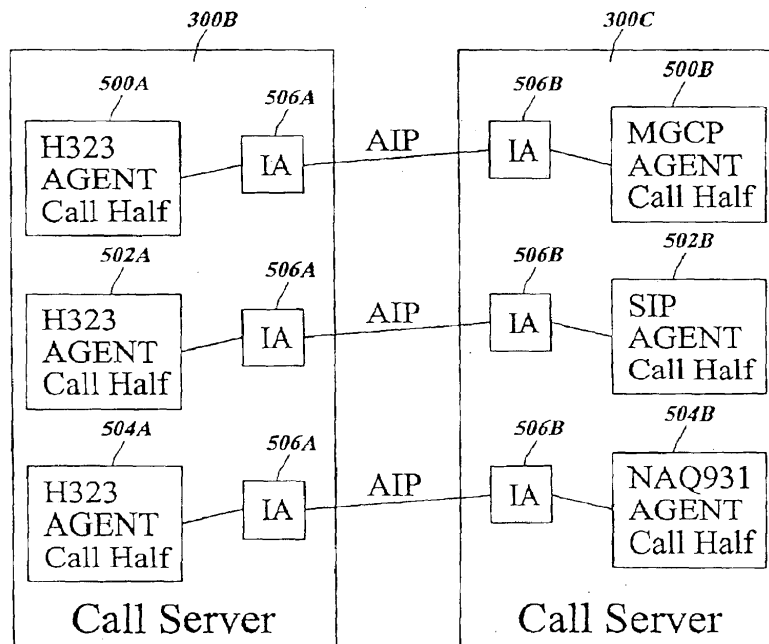

FIG. 6

Ress further describes Figure 6, above, as illustrating that “call server 300 illustrated in FIG. 5 is divided into call servers 300A, 300B, and 300C, which can execute on the same machine or on different machines.” Ex. 1004, 5:45–48. Ress discloses that “[t]his division of call processing functionality is enabled by interworking agents components 506A and 506B, which enable protocol agents to communicate with each other using AIP messaging.” *Id.* at 5:51–55. And, “[b]y allowing the protocol agents to reside on separate machines, the interworking agents according to

embodiments of [Ress] allow efficient division of call processing functions.” *Id.* at 5:58–61.

The evidence supports that Ress teaches the claimed network interface of limitation 7[e]. Petitioner asserts that the Ress’s call server corresponds to the claimed “communication controller.” Pet. 42. As Petitioner explains, consistent with Ress’s disclosures, “the interim protocol is transmitted between different endpoints, each containing its own interworking agent and call agent,” as depicted in Figure 6 of Ress. Pet. Reply 17 (citing Ex. 1004, 5:45–47). We agree with Petitioner’s argument that the different machines running the call server can be endpoints, similar to gateways, as the machines may serve as the claimed “target communication end-point.” *Id.*

Patent Owner argues that Petitioner’s assertion that claim 7[e] claims a distributed system similar to the one of Ress’s Figure 6 is based on an incorrect claim construction. PO Sur-Reply 15. Patent Owner, however, fails to explain how this contention applies to Petitioner’s arguments regarding Ress’s disclosures.

In addition to the arguments and evidence considered above, we have considered Patent Owner’s arguments concerning objective indicia of nonobviousness below. PO Resp. 49–55. For the reasons discussed, we find that Patent Owner’s evidence purportedly showing long-felt need, unexpected results, and industry praise, does not outweigh Petitioner’s evidence concerning the obviousness of claim 7. On the full record, Petitioner has established by a preponderance of the evidence that claim 7 would have been obvious over Ress.

*c. Independent Claim 11*

Independent claim 11 recites a method for multimedia communication having limitations that parallel most of the steps of claim 1. *Compare* Ex.

IPR2019-01233

Patent 7,773,588 B2

1001, 7:26–41, *with id.* at 8:51–9:6. Claim 11 additionally recites that the conversion of the first protocol into the second protocol is performed “irrespective of a second protocol in which the multimedia data stream is to be transmitted to a target communication device.” *Id.* at 8:63–65. Petitioner asserts that the intermediate AIP protocol in Ress “is designed to be ‘protocol-independent’ regardless of which protocols the endpoints use.” Pet. 48–49 (citing Ex. 1004, 6:13–19 (“Because the interworking agent components 702A and 702B provide functions for converting messages to and from a protocol independent format, MGCP agent 700A and the H.323 agent 700B need not be aware of each other’s protocol.”))).

We have reviewed Petitioner’s explanations and supporting evidence as to how Ress teaches the limitations of claim 11, and we agree with and adopt Petitioner’s analysis. *See* Pet. 47–49.

Patent Owner argues that claim 11 is not rendered obvious based on the arguments presented for claim 1. PO Resp. 39. We do not find the arguments persuasive for the reasons discussed above.

We have considered Patent Owner’s arguments concerning objective indicia of nonobviousness below. PO Resp. 49–55. For the reasons discussed, we find that Patent Owner’s evidence purportedly showing long-felt need, unexpected results, and industry praise, does not outweigh Petitioner’s evidence concerning the obviousness of claim 11. On the full record, Petitioner has established by a preponderance of the evidence that claim 11 would have been obvious over Ress.

*d. Independent Claim 18*

Independent claim 18 is an apparatus claim to a “computer program product” with limitations that parallel most of the limitations in claims 1 and 11, respectively. *Compare* Ex. 1001, 7:26–41 *with id.* at 8:19–37, 9:54–



10:13. Petitioner relies on the assertions made as to claims 1 and 11 and additionally contends that Ress discloses that its call server “is a software entity that can execute on a single machine or on multiple machines.” *See* Pet. 52–54 (citing Ex. 1004, 4:46–48).

We have reviewed Petitioner’s explanations and supporting evidence as to how Ress teaches the limitations of claim 18, and we agree with and adopt Petitioner’s analysis. *See* Pet. 52–54.

Patent Owner argues that claim 18 is not rendered obvious based on the arguments presented for claims 1 and 11. PO Resp. 39. We do not find the arguments persuasive for the reasons discussed above.

We have considered Patent Owner’s arguments concerning objective indicia of nonobviousness below. PO Resp. 49–55. For the reasons discussed, we find that Patent Owner’s evidence purportedly showing long-felt need, unexpected results, and industry praise, does not outweigh Petitioner’s evidence concerning the obviousness of claim 18. On the full record, Petitioner has established by a preponderance of the evidence that claim 18 would have been obvious over Ress.

*e. Dependent Claim 2*

Claim 2 depends from claim 1 and additionally recites:

communicating, prior to said translating, said multimedia data stream in said communication controller to a second communication controller connected to said target communication device; wherein said translating and said transmitting are performed by said second communication controller.

Ex. 1001, 7:43–48.

Petitioner relies upon the evidence and arguments provided for limitations 1[d] and [e]. Pet. 31. Petitioner also relies on Figure 6 of Ress

IPR2019-01233

Patent 7,773,588 B2

for its disclosure that call servers can execute on the same machine or different machines. *Id.*

Patent Owner argues that claim 2 is not rendered obvious based on the arguments presented for claim 1. PO Resp. 26. Patent Owner asserts that “the call server of Ress is focused solely on interworking of different call signaling protocols and does not receive, let alone process any media messages within a multimedia data stream.” *Id.* at 27. This argument is based on Patent Owner’s proposed construction of the term “multimedia data stream.” We do not find this argument persuasive because we have not adopted Patent Owner’s claim construction.

We have considered Patent Owner’s arguments concerning objective indicia of nonobviousness below. PO Resp. 49–54. For the reasons discussed, we find that Patent Owner’s evidence purportedly showing long-felt need, unexpected results, and industry praise, does not outweigh Petitioner’s evidence concerning the obviousness of claim 2. On the full record, Petitioner has established by a preponderance of the evidence that claim 2 would have been obvious over Ress.

*f. Dependent Claim 3*

Claim 3 depends from claim 1 and additionally recites:

[a] accessing a first protocol table responsive to said type, wherein said first protocol table includes a plurality of first protocol messages corresponding to a plurality of intermediate protocol messages;

[b] selecting ones of said plurality of intermediate protocol messages that correspond to one or more first protocol messages found in said multimedia data stream; and

[c] assembling said ones of said plurality of intermediate protocol messages to form said multimedia data stream in said intermediate protocol.

Ex. 1001, 7:50–61 (sub-paragraphing added).

Petitioner asserts that the recited first protocol table is the connection information parameter (CIP) data structure table disclosed in Figure 8 of Ress. Pet. 32. Petitioner asserts that values 810 are first protocol messages corresponding to intermediate protocol messages that are supported by the AIP. *Id.* (citing Ex. 1004, code (57) (“The [intermediate protocol AIP] is a superset of functions provided by the first and second protocols.”), 3:18–20 (“The [AIP] provides a superset of the functions provided by the first and second protocols.”)). Petitioner further asserts that Ress’s sending protocol agent determines whether the received message in the first protocol corresponds to a message understood by the intermediate AIP protocol, as shown in Figure 9(a). *Id.* at 33–34. Petitioner also contends that Ress teaches assembling intermediate protocol messages to form multimedia data streams, as depicted in Figure 9(a). *Id.* at 34–35.

For limitation 3[a], Patent Owner argues that the Petition points to the “media description values” of the connection information parameter (CIP) data structure of Figure 8 to disclose a “first protocol table,” but the field values do not indicate a type of protocol because AIP is intended to be a protocol independent format. PO Resp. 28 (citing Ex. 2009 ¶¶ 123–124). Patent Owner also asserts that the claim requires “accessing a first protocol table responsive to said type,” but the Petition fails to provide explanation as to how the CIP is accessed, or accessed “responsive to said type.” *Id.*

We do not find Patent Owner’s arguments persuasive. As discussed above for limitation 1[b], we have already determined that Petitioner has demonstrated that Ress discloses detection of a first protocol type and claim 3 does not require that the type of first protocol be included in the first protocol table. As Petitioner argues, Ress discloses that “[t]he connection

information parameter [CIP] illustrated in FIG. 8 is the mechanism provided by the agent interworking protocol for implementing media management functions and exchanging media capabilities.” Pet. Reply 12 (citing Ex. 1004, 8:9–12). With the detection of a first protocol type under limitation 1[b] (from which claim 3 depends), Ress teaches that the CIP of Table 8 (the first protocol table) would be used or accessed as part of the mechanism provided by the agent interworking protocol to implement media management functions and exchanging media capabilities. *See* Ex. 1004, 8:9–12. Thus, we determine that Petitioner has sufficiently demonstrated that Ress teaches “accessing a first protocol table responsive to said type” in response to the detection of a first protocol.

Patent Owner additionally asserts that Petitioner fails to demonstrate that Ress teaches limitation 3[c] because it does not process a multimedia stream. PO Resp. 29. This argument is based on Patent Owner’s proposed construction of the term “multimedia data stream.” We do not find this argument persuasive because we have not adopted Patent Owner’s proposed claim construction.

We have considered Patent Owner’s arguments concerning objective indicia of nonobviousness below. PO Resp. 49–55. For the reasons discussed, we find that Patent Owner’s evidence purportedly showing long-felt need, unexpected results, and industry praise, does not outweigh Petitioner’s evidence concerning the obviousness of claim 3. On the full record, Petitioner has established by a preponderance of the evidence that claim 3 would have been obvious over Ress.

*g. Dependent Claim 4*

Claim 4 depends from claim 1 and further recites

[a] determining a second protocol type associated with said target communication device;

[b] accessing a second protocol table responsive to said second protocol type, wherein said second protocol table includes a plurality of second protocol messages corresponding to said plurality of intermediate protocol messages;

[c] selecting ones of said plurality of second protocol messages that correspond to one or more intermediate protocol messages found in said multimedia data stream; and

[d] assembling said ones of said plurality of second protocol messages to form said multimedia data stream in said second protocol.

Ex. 1001, 7:62–8:10 (sub-paragraphing added).

Petitioner asserts that Ress teaches that as part of translating from intermediate AIP protocol to the second protocol at the target communication device, the interworking agent determines the second protocol. Pet. 35–36. Petitioner argues that Ress teaches limitation 4[b] by its disclosure of channel operation values 810 of Figure 8, and the supported operations are second protocol messages (e.g., no action, open, close, modify, mode change, redirect, direct, send capabilities). *Id.* at 37 (citing Ex. 1004, 8:16–18, 8:34–36, Fig. 8; Ex. 1002 ¶¶ 76, 79–80, 112). Petitioner contends that the API’s provision of a superset of functions “mean[s] the second protocol messages correspond to messages (e.g., functions) in the intermediate AIP protocol.” *Id.* (citing Ex. 1004, 3:18–20). Petitioner argues that Ress discloses the selection of second protocol messages at step ST8 of Figure 9. *Id.* at 38. Further, for limitation 4[d], Petitioner asserts that Ress teaches assembling second protocol messages at step ST9 of Figure 9(b) for transmitting to end user devices. *Id.* at 38–39 (citing Ex. 1004, 10:18–21, Fig. 9(b)).

We have reviewed Petitioner’s explanations and supporting evidence as to how Ress teaches the limitations of claim 4, and find that Petitioner provides sufficient support for Ress’s teachings of the claim 4 limitations. *See* Pet. 35–39; Pet. Reply 13–14.

Patent Owner argues that Petitioner has failed to demonstrate that limitation 4[a] is taught by Ress for the same reasons provided for limitation 1[b]. PO Resp. 29–30. Patent Owner also argues that the receiving protocol agent of Ress does not perform the claimed “determining” step because it already knows what protocol to use to communicate, which is confirmed by Ress’s disclosures. *Id.* at 30 (citing Ex. 2009 ¶¶ 129–130). We have addressed Patent Owner’s arguments based on limitation 1[b] and do not find them persuasive for claim 4 for reasons similar to those discussed above. We note that the discussion for limitation 1[b] addressed Patent Owner’s argument that Ress would know what protocol to use without making a “determination,” and for similar reasons, we do not find that Patent Owner’s argument on “determining” is persuasive for limitation 4[a] either.

For limitation 4[b], Patent Owner argues that Petitioner has failed to demonstrate that it is taught by Ress for the same reasons it provides for limitation 3[a]. PO Resp. 30. We do not find these arguments to be persuasive for the reasons discussed above for limitation 3[a].

For limitation 4[d], Patent Owner argues that Petitioner relies on the receipt and processing of AIP messages by “receiving protocol agent” as teaching this claim element, but “this disclosure is fundamentally inapposite with the claimed ‘assembling’ step because the received AIP messages in Ress would need to be disassembled, in order for it to be further processed.” PO Resp. 30 (citing Pet. 38–39; Ex. 2009 ¶¶ 138–140).

Patent Owner's argument on limitation 4[d] lacks merit because it misinterprets Ress. As shown in Figure 9(b) of Ress, the system receives a message (ST6), and at step ST7 it determines the message type. Ex. 1004, 10:10–17. If the message is an AIP type, “the receiving protocol agent processes the message (step ST9).” *Id.* at 10:18–21. We agree with Petitioner that this step would include assembling the second protocol messages into a multimedia data stream in a second protocol, as Dr. Lavian testifies. *See* Ex. 1002 ¶ 114; Ex. 1017 ¶ 28.

We have considered Patent Owner's arguments concerning objective indicia of nonobviousness below. PO Resp. 49–55. For the reasons discussed, we find that Patent Owner's evidence purportedly showing long-felt need, unexpected results, and industry praise, does not outweigh Petitioner's evidence concerning the obviousness of claim 4. On the full record, Petitioner has established by a preponderance of the evidence that claim 4 would have been obvious over Ress.

#### *h. Dependent Claim 5*

Claim 5 depends from claim 4 and further recites:

retrieving said second protocol type from a device information base, wherein said device information base contains compatibility information for each device available for said multimedia communication.

Ex. 1001, 8:11–15. Petitioner asserts that the data structure of Figure 8 of Ress contains compatibility information for each device. Pet. 39. Petitioner refers to field 818, which identifies the “list of supported formats,” and field 802, which contains a “media type value . . . for specifying the type of media being exchanged or sought to be exchanged in a media stream,” of Figure 8 as the device information base. *Id.* at 40 (citing Ex. 1004, 8:24–26, 8:56–65, 13:62–65).

Petitioner also asserts that, to the extent the Board finds that Ress does not disclose the additional limitation of claim 5, it would have been obvious to implement the system of Ress to retrieve the second protocol type from a device information base because a person of ordinary skill in the art would have understood that the ability to convert between two protocols requires information regarding compatible protocols for various devices in order to understand how to perform the conversion. Pet. 40–41 (citing Ex. 1002 ¶¶ 66–73, 116). Petitioner contends that a person of ordinary skill in the art would understand that the second protocol type could be stored in a database such as the claimed device information base and “a database is simply a collection of data such as the individual data structures disclosed in Ress.” *Id.* at 41.

Patent Owner argues that the Petition fails to identify the portions of Ress that Petitioner contends are the claimed compatibility information. PO Resp. 31. Patent Owner asserts that the CIP of Ress does not disclose a device information base containing compatibility information as claimed. *Id.* (citing Ex. 2009 ¶¶ 141–144).

Patent Owner additionally argues that the CIP of Ress is a data structure included within AIP messages to facilitate the exchange of specific messages between terminal devices in a particular communication session, but a person of skill would not have understood the CIP to contain “compatibility information for *each device available* for said multimedia communication.” PO Resp. 31 (citing Ex. 1004, 8:9–15; Ex. 2009 ¶ 143<sup>9</sup>). Patent Owner argues that Petitioner fails to explain how multiple ephemeral

---

<sup>9</sup> Patent Owner’s Response cites to “Ex. 2009 ¶ 144,” but in context the citation appears to be incorrect and the most relevant paragraph of the Declaration cited above.



communication-specific data structures constitute “a device information base.” PO Sur-Reply 14.

We are persuaded by Patent Owner’s argument that Petitioner fails to demonstrate that Ress teaches a “device information base [that] contains compatibility information for each device available for said multimedia communication” as recited in claim 5. We agree with Patent Owner’s contention that the evidence supports that the CIP illustrated in Figure 8 of Ress is a data structure provided by the AIP to facilitate the exchange of specific messages between terminal devices in a communication session. *See* PO Resp. 31; Ex. 1004, 8:9–15. As such, that disclosure alone does not sufficiently demonstrate that Ress teaches the storage of compatibility information in a device information base for each device that is available for multimedia communication, as claim 5 requires. We credit Dr. Jeffay’s testimony on this issue, that is, that Ress’s Figure 8 table is disclosed as a connection specific table. Ex. 2009 ¶ 143. Ress’s disclosure describes some of the fields in Ress’s Figure 8 table as providing characteristics of a “current media stream,” which supports Dr. Jeffay’s testimony. *See* Ex. 1004, 8:52–54. Although Dr. Lavian testifies that “each device communicating through the call server would have associated CIPs to facilitate a conversion,” that testimony is not sufficient to support that Ress discloses the capability to store that data for available devices, but rather could be viewed as applying only to those devices in a particular communication session. Ex. 1017 ¶ 29.

Accordingly, we determine that Petitioner has not established by a preponderance of the evidence that claim 5 would have been obvious over Ress.

*i. Dependent Claim 6*

Claim 6 depends from claim 1 and further recites “wherein said intermediate protocol comprises protocol messages common to said text-based protocol and said binary protocol.” Ex. 1001, 8:16–18.

Petitioner asserts that Ress discloses that intermediate protocol AIP “is preferably capable of representing a reasonable superset of the messaging capabilities of all protocols to be supported within the packet network,” so the AIP comprises a superset of functions, or messages, common to supported protocols such as H.323 and SIP. Pet. 41–42.

Patent Owner argues that a person of ordinary skill in the art “would understand the ‘capability’ of a message in Ress as referencing the function performed by the message, and not a requirement that actual protocol messages be present within the AIP.” PO Resp. 33 (citing Ex. 2009 ¶ 146).

In Reply, Petitioner argues, and we agree, that Patent Owner’s argument assumes a narrow interpretation of the claim language that would render the additional limitation of claim 6 meaningless because a person of ordinary skill would understand that different protocols do not have messages that are literally identical. Pet. Reply 15 (citing Ex. 1017 ¶ 31). In support, Petitioner references the portion of the ’588 patent that recognizes this by referring to “an interim protocol that comprises the common functions and elements of the different protocols.” *Id.* (citing Ex. 1001, 3:36–37).

We have reviewed Petitioner’s explanations and supporting evidence as to how Ress teaches the additional limitation of claim 6, and we agree that Petitioner has sufficiently shown that Ress teaches the limitation of the claim. *See* Pet. 41–42; Pet. Reply 15–16.

We have considered Patent Owner's arguments concerning objective indicia of nonobviousness below. PO Resp. 49–55. For the reasons discussed, we find that Patent Owner's evidence purportedly showing long-felt need, unexpected results, and industry praise, does not outweigh Petitioner's evidence concerning the obviousness of claim 6. On the full record, Petitioner has established by a preponderance of the evidence that claim 6 would have been obvious over Ress.

*j. Dependent Claims 8–10, 12–17, and 19–23*

Petitioner asserts that Ress discloses the limitations of claims 8–10, 12–17, and 19–23 based on the evidence and argument presented for other claims. *See* Pet. 46–47, 49–52, 54–56. We find that Petitioner has not demonstrated that Ress teaches the limitations of claims 15 and 22 because Petitioner relies upon the same evidence and argument presented for claim 5, which we have found to be deficient. *See* Pet. 51, 56.

We have reviewed Petitioner's explanations and supporting evidence as to how Ress teaches the limitations of claims 8–10, 12–14, 16, 17, 19–21, and 23, and we agree with, and adopt Petitioner's analysis.

Patent Owner argues that claims 8–10, 12–14, 16, 17, 19–21, and 23 are not rendered obvious based on arguments directed to other claims, which we have already considered. PO Resp. 38–40. We do not find the arguments persuasive for the reasons discussed above.

We have considered Patent Owner's arguments concerning objective indicia of nonobviousness below. PO Resp. 49–55. For the reasons discussed, we find that Patent Owner's evidence purportedly showing long-felt need, unexpected results, and industry praise, does not outweigh Petitioner's evidence concerning the obviousness of claims 8–10, 12–14, 16, 17, 19–21, and 23. On the full record, Petitioner has established by a

IPR2019-01233

Patent 7,773,588 B2

preponderance of the evidence that claims 8–10, 12–14, 16, 17, 19–21, and 23 would have been obvious over Ress.

*k. Objective Indicia of Nonobviousness*

Patent Owner also presents arguments and evidence of objective indicia or secondary considerations of nonobviousness. PO Resp. 49–55; PO Sur-Reply 21–25. Objective indicia of nonobviousness may include long-felt but unsolved need, failure of others, unexpected results, commercial success, copying, licensing, industry praise, and expert skepticism. *Mintz v. Dietz & Watson, Inc.*, 679 F.3d 1372, 1379 (Fed. Cir. 2012). “[O]bjective indicia may often be the most probative and cogent evidence of nonobviousness in the record,” and “help turn back the clock and place the claims in the context that led to their invention.” *Id.* at 1378. Evidence of objective indicia of nonobviousness “must always when present be considered en route to a determination of obviousness.” *Transocean Offshore Deepwater Drilling, Inc. v. Maersk Drilling USA, Inc.*, 699 F.3d 1340, 1349 (Fed. Cir. 2012); *see also Apple Inc. v. Samsung Elecs. Co.*, 839 F.3d 1034, 1048 (Fed. Cir. 2016) (en banc).

Objective indicia of nonobviousness are “only relevant to the obviousness inquiry ‘if there is a nexus between the claimed invention and the [objective indicia of nonobviousness].’” *In re Affinity Labs of Tex., LLC*, 856 F.3d 883, 901 (Fed. Cir. 2017) (quoting *Ormco Corp. v. Align Tech., Inc.*, 463 F.3d 1299, 1312 (Fed. Cir. 2006)). For objective indicia of nonobviousness to be accorded substantial weight, their proponent must establish a nexus between the evidence and the merits of the claimed invention. *ClassCo, Inc. v. Apple, Inc.*, 838 F.3d 1214, 1220 (Fed. Cir. 2016).

As the Federal Circuit has explained, “a patentee is entitled to a rebuttable presumption of nexus between the asserted evidence of secondary considerations and a patent claim if the patentee shows that the asserted evidence is tied to a specific product and that the product ‘is the invention disclosed and claimed.’” *Fox Factory, Inc. v. SRAM, LLC*, 944 F.3d 1366, 1373 (Fed. Cir. 2019) (quoting *Demaco Corp. v. F. Von Langsdorff Licensing Ltd.*, 851 F.2d 1387, 1392 (Fed. Cir. 1988)). That is, presuming nexus is appropriate “when the patentee shows that the asserted objective evidence is tied to a specific product and that product ‘embodies the claimed features, and is coextensive with them.’” *Id.* (quoting *Polaris Indus., Inc. v. Arctic Cat, Inc.*, 882 F.3d 1056, 1072 (Fed. Cir. 2018)). On the other hand, the patentee is not entitled to a presumption of nexus if the patented invention is only a component of a commercially successful machine or process. *Id.* Once “the patentee has presented a prima facie case of nexus, the burden of coming forward with evidence in rebuttal shifts to the challenger . . . to adduce evidence to show that the commercial success was due to extraneous factors other than the patented invention.” *Demaco*, 851 F.2d at 1392–93.

However, “[a] finding that a presumption of nexus is inappropriate does not end the inquiry into secondary considerations.” *Fox Factory*, 944 F.3d at 1373. “To the contrary, the patent owner is still afforded an opportunity to prove nexus by showing that the evidence of secondary considerations is the ‘direct result of the unique characteristics of the claimed invention.’” *Id.* at 1373–74 (quoting *In re Huang*, 100 F.3d 135, 140 (Fed. Cir. 1996)). “Ultimately, the fact finder must weigh the secondary considerations evidence presented in the context of whether the claimed invention as a whole would have been obvious to a skilled artisan.”

IPR2019-01233

Patent 7,773,588 B2

*Lectrosonics, Inc. v. Zaxcom, Inc.*, IPR2018-01129, Paper 33 at 33 (PTAB Jan. 24, 2020) (precedential) (citing *WBIP, LLC v. Kohler Co.*, 829 F.3d 1317, 1331 (Fed. Cir. 2016)).

*i. Presumption of Nexus*

Patent Owner argues that the challenged claims are embodied in its Secure Traversal Navigation Solution system (the “STNS system”). PO Resp. 50 (citing Ex. 2008; Ex. 2009 ¶¶ 190–192; Ex. 2028). Patent Owner refers to the Declaration of Rahul Vijn for support, with Mr. Vijn testifying that he considered “Source Code for directPacket’s STNS system” and, based on his review, the STNS system embodies the inventions of claims 1–23 of the ’588 patent. Ex. 2008 ¶¶ 9, 17. Mr. Vijn refers to a claim chart, which purports to identify source code for each element of the claims. *Id.* ¶ 17, App. B. Patent Owner contends that when a marketed product embodies the claimed invention, objective evidence may be presumptively attributed to the patented invention. PO Resp. 50 (citing *PPC Broadband, Inc. v. Corning Optical Commc’ns RF, LLC*, 815 F.3d 734, 747 (Fed. Cir. 2016)).

Patent Owner refers to the testimony of Dr. Jeffay, who references the Declaration of Mr. Vijn and relies upon it for his opinion that the challenged claims are embodied in the STNS system. Ex. 2009 ¶ 190. Patent Owner also relies on Dr. Jeffay’s review of a report by market research firm Wainhouse Research (the “Wainhouse report”) (Ex. 2028), which provide the results of testing of Patent Owner’s STNS system. Ex. 2009 ¶ 191.

Patent Owner argues that Petitioner fails to directly respond to and rebut the testimony provided by Dr. Jeffay and Mr. Vijn. PO Sur-Reply 23–24. More specifically, Patent Owner asserts that Dr. Jeffay provides un rebutted testimony regarding how the objective evidence offered is

IPR2019-01233

Patent 7,773,588 B2

reasonably commensurate with the scope of the challenged claims. *Id.* at 24 (citing Ex. 1037, 201:18–205:16; *Rambus Inc. v. Rea*, 731 F.3d 1248, 1257 (Fed. Cir. 2013)).

As Petitioner argues, however, Patent Owner does not provide sufficient analysis demonstrating that the STNS system was coextensive (or nearly coextensive) with the challenged claims. *See* Pet. Reply 25–28. The main evidence of a nexus presented by the Patent Owner is the Vijh Declaration, but Mr. Vijh’s testimony on the issue merely consists of the statement that he examined source code for the STNS system, and “it is my opinion that directPacket’s STNS system practices and embodies the inventions recited in Claims 1–30 of the ’588 Patent.” Ex. 2008 ¶¶ 9, 17. Mr. Vijh also states that in support of this opinion, he “compiled a claim chart identifying, on a claim element-by-claim element basis, where in the STNS Source Code each element of Claims 1–23 of the ’588 Patent is found,” which is attached as Appendix B of the Declaration. Appendix B, however, only presents as support for each claim element a listing of subroutine names without additional detail, such as the source code for the subroutine or an explanation of its contents or operation. *See id.* ¶ 17, App. B.<sup>10</sup> Moreover, none of the source code for the STNS system was produced by Patent Owner. *See id.* Thus, Patent Owner has not provided Petitioner or the Board with sufficient information to understand the basis for Mr. Vijh’s opinion or to evaluate its accuracy. Accordingly, because the testimony is

---

<sup>10</sup> Patent Owner filed a Motion to Seal, which seeks to seal of portions of Appendix B of the Vijh Declaration, and, more particularly, seeks to seal the names of portions of the source code. Paper 31; Ex. 2008. We address the Motion to Seal below, but note that the discussion herein does not disclose the identification of portions of the source code that are alleged to be confidential.

conclusory and not supported by evidence of record, we cannot credit Mr. Vijh's testimony concerning the alleged practice of the claims by the STNS system. 37 C.F.R. § 42.65(a) ("Expert testimony that does not disclose the underlying facts or data on which the opinion is based is entitled to little or no weight.").

Patent Owner also relies on the testimony of Dr. Jeffay, who refers to the Vijh Declaration, and states that "I find the [Mr. Vijh's] analysis credible" and "the conclusions developed are supported by the analysis presented." Ex. 2009 ¶ 190. Dr. Jeffay continues: "[f]or these reasons, it is my opinion" that the claims are embodied by the STNS system. *Id.* (emphasis added). We cannot afford weight to this portion of Dr. Jeffay's testimony because Dr. Jeffay does not base his opinion on his own independent evaluation of the source code and rather relies upon that the testimony of Mr. Vijh, which we find to be insufficiently supported and conclusory, as discussed above.

We also are not persuaded by Dr. Jeffay's reliance on the Wainhouse report. *See* Ex. 2009 ¶ 191. Dr. Jeffay testifies that "the [Wainhouse] [r]eport provides the results of extensive testing of the Patent Owner's STNS system which has been shown to embody the inventions of the '588 Patent." *Id.* Patent Owner additionally refers to Dr. Jeffay's deposition testimony as support for the allegation that Mr. Vijh's opinions are corroborated by the Wainhouse report. PO Sur-Reply 23 (citing Ex. 1019, 195:11–200:8).

The Wainhouse report documents an evaluation of the STNS system, including testing, with assessment of different criteria, such as install/configure difficulty, user interface, connectivity, interoperability, feature sets, security, and costs. Ex. 2028, 1–4. Although the Wainhouse report includes testing protocols and results, it does not provide any details



on the STNS system itself or its operation. *See generally id.* Similarly, as discussed above, Dr. Jeffay’s testimony references the Wainhouse report, but provides no discussion or explanation of how the claim elements are embodied in the STNS system. *See* Ex. 2009 ¶¶ 191–192; Ex. 2028, 2, 4, 17, 20; Ex. 1019, 195:11–200:8. Instead, Dr. Jeffay testifies, in a conclusory manner, that “the [Wainhouse] Report confirms my opinion that the Challenged Claims are embodied by Patent Owner.” Ex. 2009 ¶ 191. In view of the lack of information on the STNS system and its operation in the Wainhouse report, and Dr. Jeffay’s failure to provide supporting explanations with sufficient detailed explanations, we cannot credit Dr. Jeffay’s testimony on the alleged nexus, and the Wainhouse report does not serve to corroborate Mr. Vjih’s opinion that the challenged claims are embodied in the STNS system.

Thus, based on the evidence of record, Patent Owner does not provide sufficient analysis demonstrating that the infringing products were coextensive (or nearly coextensive) with the challenged claims. *See* PO Resp. 49–50. We, therefore, find that a presumption of nexus is inappropriate. *See Lectrosonics*, Paper 33 at 33; *Fox Factory*, 944 F.3d at 1374.

*ii. Long-Felt Need*

Patent Owner asserts that its STNS system satisfied a long-felt but unmet need for a method of multimedia communication that provided enhanced interoperability, that is, compatibility across multiple manufacturers, and transparency, without sacrificing any quality of service. PO Resp. 51–52 (citing Ex. 2009 ¶¶ 191–192). Patent Owner asserts that as the Internet matured and network links had increased capacity, the desire to conduct multimedia communication sessions across disparate,

IPR2019-01233

Patent 7,773,588 B2

geographically distant networks grew and several technical challenges needed to be resolved. *Id.* at 51. Patent Owner further argues that efforts to address these issues began shortly after the H.323 and SIP protocols were developed, yet despite the significant attention devoted to the issue in academia and industry, no solution had emerged. *Id.*

Patent Owner contends that its STNS system satisfied this long-felt need because it “marked a significant advancement in the technology and addressed a critical problem, which theretofore had plagued the videoconferencing industry.” PO Resp. 52 (citing Ex. 2009 ¶¶ 191–192). Patent Owner argues that because the STNS solution solved known issues without adversely impacting overall call quality and user experience, the claims satisfied a long-felt but unmet need. *Id.* (citing Ex. 2028, 12, 17). Patent Owner further asserts that the objective results of the study discussed in the Wainhouse report found that the STNS system overcame the known obstacles in the field to provide seamless communication and highlighted its “Exceptional Interoperability” and “Transparent Operation.” PO Sur-Reply 24–25 (citing Ex. 2028, 20).

Establishing long-felt need “requires objective evidence that an art-recognized problem existed in the art for a long period of time without solution.” *Ex parte Jellá*, Appeal No. 2008-1619, 2008 WL 5693899, at \*13 (BPAI Nov. 3, 2008) (precedential). Furthermore, one must demonstrate that “widespread efforts of skilled workers having knowledge of the prior art had failed to find a solution to the problem.” *In re Allen*, 324 F.2d 993, 997 (CCPA 1963).

Petitioner argues that the STNS system did not satisfy a long-felt but unmet need. Pet. Reply 28–29. Petitioner asserts that as of December 2004, numerous products were already in commercial use that allowed multimedia

communication across disparate networks. *Id.* (citing Ex. 1002 ¶¶ 51, 55–68; Ex. 1017 ¶ 43). In support, Dr. Lavian testifies that by December 2004, H.323 and SIP were mature technologies that had been around for years. Ex. 1017 ¶ 44. Dr. Lavian further testifies that at that time, the industry understood how to communicate across disparate geographic networks using H.323 and SIP. *Id.*

We are not persuaded that Patent Owner has provided sufficient evidence to establish a long-felt need that the claimed invention satisfied. Patent Owner relies on the Wainhouse report for support that the STNS system allegedly solved long-felt needs; however, the report makes general statements about the STNS system, but it does not indicate that the STNS system solved protocol conversion issues.<sup>11</sup> Ex. 2028, 20. Additionally, Dr. Jeffay’s testimony on long-felt need only provides general statements on the issue. Ex. 2009 ¶ 191; Ex. 1019, 195:11–200:8.

Moreover, the lack of any evidence of actual sales or customer use of the STNS system cuts against Patent Owner’s assertion that this system satisfied long-felt but unmet needs of customers. And, Patent Owner does not show a nexus between the alleged long-felt needs and the merits of the claimed invention; Patent Owner provides no additional evidence to demonstrate that the STNS system attributes met long-felt needs.

---

<sup>11</sup> The Wainhouse report states “STNS *does not interfere* with the capabilities exchange or protocols/resolutions used by the participating video systems.” Ex. 2028, 20 (emphasis added); *see also id.* at 15 (noting limitations in protocol support), *id.* at 17 (noting support for limited protocols).

*iii. Unexpected Results*

Patent Owner asserts that there were real-world constraints at the time of the '588 patent that imposed significant obstacles for multimedia communications. PO Resp. 52. Patent Owner argues that “real-time conversion of multimedia data streams line-by-line, bit-by-bit, as a general matter, requires processing vast amounts of data, both in terms of number of packets as well as quantum of data.” *Id.* at 52–53 (citing Ex. 2009 ¶¶ 186–191). Patent Owner asserts that a person of ordinary skill would have expected that the additional computational overhead required for conversion would be unduly burdensome, “rendering the systems at the time inoperable by sacrificing the basic level of call quality needed for communication.” *Id.* at 53 (citing Ex. 2009 ¶¶ 186–191). Further, Patent Owner asserts that the '588 patent inventor's ability to clear these hurdles was “seamless,” and accomplished what no person of ordinary skill in the art would have expected was possible. *Id.* at 53 (citing Ex. 2028; Ex. 2009 ¶¶ 191–192; Ex. 2008).

We agree with Petitioner's argument that Patent Owner does not identify how the STNS system was any different than products that were on the market at the time. *See* Pet. Reply 30. To establish unexpected results, the claimed subject matter must be compared with the closest prior art. *In re Baxter Travenol Labs.*, 952 F.2d 388, 392 (Fed. Cir. 1991). The evidence of record indicates that there were other products in the market that allowed multimedia communications between external networks. *See* Ex. 2028, 2; Ex. 1017 ¶ 43. Patent Owner provides no evidence explaining the differences between the STNS system and other systems. *See* PO Resp. 52–53. Furthermore, the lack of any evidence of actual sales or customer use of the STNS system cuts against Patent Owner's assertion that this system's

IPR2019-01233

Patent 7,773,588 B2

operation had unexpected results. And, Patent Owner fails to show a nexus between the alleged unexpected results and the merits of the claimed invention; Patent Owner provides no additional evidence to demonstrate that the STNS system attributes produced unexpected results.

*iv. Significant Industry Praise*

Patent Owner asserts that the STNS system received significant industry praise from industry thought leaders. PO Resp. 53–54. More specifically, Patent Owner asserts that Wainhouse, a respected analyst and thought leader in the videoconferencing industry, lauded the STNS system’s ability to “seamlessly” communicate, noting its “Exceptional Interoperability” and “Transparent Operation” as its “Primary Strengths.” *Id.* at 54 (citing Ex. 2028; Ex. 2029). Patent Owner contends that this alleged industry recognition of the features of the claims that “unexpectedly overcame the significant limitations of the prior art solutions further confirms they are nonobvious.” *Id.* at 54 (citing *Institut Pasteur & Universite Pierre Et Marie Curie v. Focarino*, 738 F.3d 1337, 1347 (Fed. Cir. 2013)).

Here, the only evidence presented in support of alleged significant industry praise is the Wainhouse report. *See* PO Resp. 54–55. We find this evidence to be insufficient to demonstrate significant industry praise. The limited nature of the evidence—one report from an evaluation company—does not rise to a level of demonstrating significant industry praise. Patent Owner fails to show a nexus between the alleged industry praise and the merits of the claimed invention; Patent Owner provides no additional evidence to demonstrate that the STNS system attributes had been found to be praiseworthy by the industry.

*v. Conclusions on Objective Indicia of  
Nonobviousness*

For the reasons explained above, we conclude that Patent Owner's evidence purportedly showing, long-felt need, unexpected results, and significant industry praise is not sufficient to outweigh Petitioner's evidence of obviousness of the challenged claims.

*1. Summary*

To summarize, we determine that Petitioner has demonstrated by a preponderance of the evidence that Ressa teaches all the limitations of claims 1–4, 6–14, 16–21, and 23 and these claims are unpatentable as obvious. We also determine that Petitioner has not demonstrated by a preponderance of the evidence that Ressa teaches all the limitations of claims 5, 15, and 22.

*E. Alleged Obviousness of Claims 1–23 Over Ressa and Doyle*

In the Petition, Petitioner contends that claims 1–23 are rendered obvious by the combination of Ressa and Doyle. Pet. 56–68. To support its contentions, Petitioner provides explanations as to how Ressa and Doyle teaches each claim limitation. *Id.* Petitioner also relies upon the Lavian Declarations (Ex. 1002; Ex. 1017) to support its positions. Patent Owner argues that the prior art asserted fails to teach or suggest some of the claim limitations and the rationale to combine the references is insufficient, with Dr. Jeffay providing supporting testimony. *See generally* PO Resp.; Ex. 2001; Ex. 2009.

We begin our discussion with a brief summary of Doyle and then address the evidence and arguments presented.

*1. Doyle (Ex. 1005)*

Doyle is directed to a multi-protocol communication analysis system with protocol conversion of multimedia communications. Ex. 1005, code

(57). Figure 2, reproduced below, depicts a block diagram showing the multi-protocol communication analysis system. *Id.* ¶ 18.

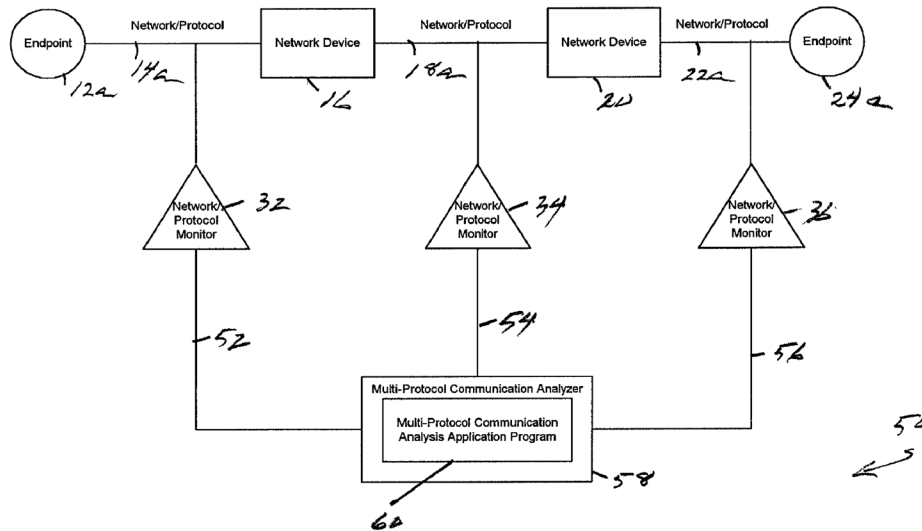

FIG. 2

Figure 2 of Doyle, above, illustrates a system for communications between endpoint 12a and endpoint 24a that includes three network/protocol monitors 32, 34, 36 that provide first, second, and third protocol information 52, 54, 56 to multi-protocol communication analyzer 58, which includes multi-protocol communication analysis application program 60. Ex. 1005 ¶¶ 37–38. Communications travel over first protocol 14a, where they are converted by network device 16 into second protocol 18a, which are then converted by network device 20 into third protocol 22a. *See id.* ¶ 30. Embodiments include the use of SIP and ISDN (*id.* at Fig. 3), and Doyle discloses that other protocols can be used including H.323, SS7, and HTTP (*id.* ¶ 55).

## 2. Analysis

In its obviousness contentions, to the extent that Ress is considered not to disclose limitation of claims of the '588 patent directed to protocols,

Petitioner relies upon Doyle in combination with Ress in the alternative. *See* Pet. 57–68.

*a. Claim 1*

Patent Owner argues that to the extent Ress is not considered to disclose claim limitation 1[b] (“detecting a type of said first protocol”), Doyle also discloses this limitation. Pet. 57. Petitioner points to Doyle’s disclosure that “[t]he method includes collecting protocol information corresponding to the plurality of protocols, wherein the collecting is provided by a plurality of network/protocol monitors.” *Id.* (citing Ex. 1005 ¶ 12). Petitioner asserts that Doyle’s network/protocol monitors provide protocol information to a multi-protocol communication analyzer, which includes a multi-protocol communication analysis application program, and the multi-protocol communication analysis application program analyzes the protocol. *Id.* (citing Ex. 1005 ¶ 60). Petitioner contends that the analysis includes detecting information regarding the monitored communication, including an “identification of a content of the communication (for example, G.711 audio media).” *Id.* (citing Ex. 1005 ¶ 39). For support, Petitioner refers to Figure 3 of Doyle and its depiction of links using different protocols for communication messaging. *Id.* at 57–58.

Petitioner asserts that Ress and Doyle are in the same field of endeavor, that is, systems for converting between multimedia, and particularly VoIP, protocols. Pet. 59 (citing Ex. 1002 ¶¶ 76–78, 81–82, 164). Petitioner contends that “[e]xplicitly detecting the first protocol is an entirely predictable variation” to a person of ordinary skill in the art. *Id.* Petitioner further contends that a person of ordinary skill in the art would understand that detecting the type of protocol used in a communication was a routine procedure and was predictable. *Id.* at 59–60. Petitioner also



asserts that Ress itself suggests detecting the first protocol. *Id.* at 60. For instance, Petitioner argues that step ST2 shown in Figure 9(a) of Ress “suggests and requires that there must be a method for detecting the first protocol, because otherwise the system of Ress would lack the information to determine whether a mapping was available.” *Id.* (citing Ex. 1002 ¶ 167).

Petitioner further argues that the functionality of Doyle to detect protocols would be added to the call server of Ress to examiner headers to determine protocol, and there would be no need to include network/protocol monitors from Doyle. Pet. Reply 22 (citing Pet. 59; Ex. 1002 ¶¶ 66–73, 99, 162–163; Ex. 1017 ¶¶ 25, 35; Ex. 1005 ¶¶ 13, 14, 24).

We have reviewed Petitioner’s explanations and supporting evidence and find that Petitioner provides sufficient support for the teaching of the claim 1 limitations by Ress and Doyle and has sufficiently supported the rationale to combine the references.

Patent Owner argues that: (1) there is no motivation to modify Ress to incorporate Doyle’s teaching; (2) the Petition fails to explain how Ress would be combined with Doyle; and (3) there is no reasonable expectation of success in combining Ress and Doyle. PO Resp. 41–45.

On the first issue, Patent Owner asserts that Doyle is not analogous art because the ’588 patent is directed toward “communication using incompatible communication protocols,” and Doyle is concerned with monitoring and analyzing network communications. PO Resp. 42; Ex. 2009 ¶ 167. Dr. Jeffay testifies that Doyle does not describe protocol conversion, and only observes traffic. Ex. 2009 ¶¶ 164, 165. Patent Owner also points to a statement made in the Decision on Institution, which states that “the technology, claims, and prior art do not specifically relate to monitoring and maintaining VoIP and multimedia networks,” to suggest that a monitoring

IPR2019-01233

Patent 7,773,588 B2

system like Doyle should not be considered analogous art. PO Resp. 42 (citing Inst. Dec. 21).

We do not find these arguments persuasive because while Doyle is directed to an analysis system, it includes analysis of protocol conversion systems for multimedia communications. Ex. 1005, code (57). Doyle's embodiments include the use of multiple protocols and their conversions. *Id.* ¶¶ 37–38, 55. As Dr. Jeffay testifies, Doyle provide a user with a visual display of how the protocols are converted by devices in the network. Ex. 2009 ¶ 165 (citing Ex. 1005 ¶ 10). The '588 patent is directed to conversion of protocols of multimedia communications. Ex. 1001, code (57). A reference is considered analogous prior art if the reference is from the same field of endeavor as the claimed subjected matter, regardless of the problem addressed. *In re Bigio*, 381 F.3d 1320, 1325 (Fed. Cir. 2004). Further, “[t]he Supreme Court’s decision in *KSR* . . . directs us to construe the scope of analogous art broadly.” *Wyers v. Master Lock Co.*, 616 F.3d 1231, 1238 (Fed. Cir. 2010). Although Doyle addresses problems using its analysis of protocol conversion of multimedia communications, it nevertheless is from the same field of endeavor as the '588 patent, that is, systems for converting protocols of multimedia communications, and is therefore analogous art.

Additionally, Patent Owner takes the cited statement on monitoring and maintaining VoIP and multimedia networks from the Decision on Institution out of context. *See* PO Resp. 42. The cited statement is from the discussion on the qualifications of a person of ordinary skill in the art, and the intent of the statement was only to indicate that a person of ordinary skill in the art was not required to have hands-on (operational) experience with monitoring and maintaining of VoIP and multimedia systems. *See* Inst. Dec. 21.

Patent Owner also argues that the Petition fails to explain why a skilled artisan would have been motivated to modify Ressa because Petitioner argues that Ressa teaches the claimed detection, so the teachings of Doyle would be redundant. PO Resp. 43–44. We do not find this argument persuasive because Petitioner argues Doyle in combination with Ressa in the alternative, if Ressa's teachings were determined to be inadequate. *See* Pet. 57.

Accordingly, we do not find persuasive Patent Owner's arguments on the rationale to combine Doyle and Ressa. And, Petitioner's rationale that Ressa requires detection of protocol and Doyle explicitly discloses protocol detection provides a requisite rationale underpinning for the combination.

For the second issue, Patent Owner argues that the Petition fails to establish how a person of ordinary skill in the art would combine Doyle with Ressa. PO Resp. 47. Patent Owner asserts that Petitioner contends that the multiprotocol communication analyzer of Doyle teaches detecting in analyzing protocol information, but Ressa does not include any network/protocol monitors, and Petitioner fails to explain how the necessary protocol information would be collected. PO Resp. 44. Thus, according to Patent Owner, the proposed modifications would not be a predictable application of a known technique. *Id.* Petitioner contends that the only functionality being combined from Doyle is detecting the type of protocol, and that could be done with a limited code without including network/protocol monitors from Doyle.<sup>12</sup> Pet. Reply 22 (citing Ex. 1002 ¶¶ 66–73, 99, 162–163; Ex. 1017 ¶¶ 25, 35).

---

<sup>12</sup> Although Patent Owner argues that Petitioner changes course from the arguments it presented in the Petition (PO Sur-Reply 19), we do not find that to be accurate. Instead, Petitioner's Reply includes additional explanations on its assertions provided in response to Patent Owner's arguments, and the

We are not persuaded by Patent Owner's arguments because Petitioner is not relying on the bodily incorporation of Doyle into Ress. *See* Pet. 57–60; Pet. Reply 22. We credit Dr. Lavian's testimony that detecting the type of protocol used in a communication was a routine procedure that a person of ordinary skill in the art would understand, and incorporating the teachings regarding detecting protocols into Ress would be no more than combining prior art elements according to known methods to yield predictable results. *See* Ex. 1002 ¶¶ 66–73, 83, 165; Ex. 1017 ¶¶ 25, 35. In particular, Dr. Lavian notes as support the known requirement of determining protocols in order accomplish protocol mapping, as well as known methods of examining headers of incoming packets to determine protocols. *See* Ex. 1002 ¶ 66; Ex. 1007 ¶ 35.

Accordingly, we do not find persuasive Patent Owner's arguments regarding Petitioner's showing of how a person of ordinary skill in the art would combine Doyle with Ress.

For the third issue, Patent Owner asserts that the Petition fails to demonstrate a reasonable expectation of success in the combination of Ress and Doyle. PO Resp. 45. Patent Owner argues that the proposed modification of Ress would entail more than “known methods to yield predictable results,” as Petitioner argues, because the design and implementation of network monitors is a complex and specialized process. *Id.*; *see* Ex. 2009 ¶ 169. In Reply, Petitioner asserts that detecting protocols is not a complex or specialized process because “[d]etecting protocol can be accomplished by examining the headers of incoming packets to determine

---

explanations fall within the original arguments made in the Petition. *See* Pet. 59–60; Ex. 1002 ¶¶ 164–165.

IPR2019-01233

Patent 7,773,588 B2

the protocol.” Pet. Reply 23 (citing Pet. 27; Ex. 1002 ¶¶ 66–73, 99; Ex. 1017 ¶¶ 25, 35).

We are not persuaded by Patent Owner’s arguments because they appear to be based on a bodily incorporation of network/protocol monitors from Doyle into Ress, which Petitioner is not asserting, as discussed above. *See* Pet. 57–60; Pet. Reply 22; Ex. 2009 ¶ 169. Additionally, we credit Dr. Lavian’s testimony that detecting protocols would be done by examining the headers of incoming packet, which is within known methods yielding predictable results, thus providing support that the combination would have worked for its intended purpose. *See* Ex. 1017 ¶¶ 25, 35; *see also DePuy Spine, Inc.*, 567 F.3d at 1326.

Accordingly, despite Patent Owner’s arguments to the contrary, we determine that Petitioner makes a persuasive showing that a person of ordinary skill in the art would have a reasonable expectation of success for the combination of Doyle with Ress.

We have considered Patent Owner’s arguments concerning objective indicia of nonobviousness above. PO Resp. 49–55. For the reasons discussed above, we find that Patent Owner’s evidence purportedly showing long-felt need, unexpected results, and industry praise does not outweigh Petitioner’s evidence concerning the obviousness of claim 1. On the full record, Petitioner has established by a preponderance of the evidence that claim 1 would have been obvious over the combination of Ress and Doyle.

*b. Claim 5*

Petitioner argues that to the extent Ress is not considered to disclose claim 5, Doyle discloses a device information base containing compatibility information for each device available for multimedia communication. Pet. 61. Petitioner asserts that Doyle discloses that “[t]he computer readable

medium includes instructions for collecting protocol information corresponding to the plurality of protocols.” *Id.* at 61 (citing Ex. 1005 ¶ 13). Petitioner refers to Doyle’s disclosure that the collected protocol information can be analyzed, stored, and displayed. *Id.* Petitioner notes Doyle’s teaching that the information regarding many protocols can be collected and stored. *Id.* at 62 (citing Ex. 1005 ¶ 55). Petitioner refers to a ladder diagram, Figure 3, as a depiction of the retrieval of protocol information. *Id.* at 62–63.

Petitioner also asserts that Doyle teaches that the device information base (the computer readable medium) may collect compatibility information for each device available for multimedia communication. Pet. 62. Petitioner refers to Figure 2 of Doyle, which shows network/protocol monitors at each communication link between each endpoint and network device. *Id.* Petitioner asserts that Doyle’s network/protocol monitors provide a variety of protocol information. Pet. 63 (citing Ex. 1005 ¶¶ 35, 39). Petitioner cites as an example of the information collected the “content of the communication, (for example, G.711 audio media),” and asserts that collecting the type of protocol the device is using (e.g., G.711, SIP, H.323, etc.) constitutes retrieving compatibility information. *Id.* at 64 (citing Ex. 1002 ¶ 173).

Petitioner argues that a person of ordinary skill in the art would have been motivated to modify Ressa to include the device information base discussed in Doyle, with a reasonable expectation of success in doing so. Pet. 64 (citing Ex. 1002 ¶¶ 69–70, 174). Petitioner asserts that both Ressa and Doyle are in the same field of endeavor. *Id.* (citing Ex. 1002 ¶¶ 76–78, 81–82, 174). Petitioner argues that maintaining a computer readable medium with compatibility information (as discussed in Doyle) is a

predictable variation to a person of skill, and it would be impossible to convert from one protocol to a second protocol as disclosed in Ressa without having compatibility information, which is a design incentive. *Id.* at 64–65 (citing Ex. 1002 ¶¶ 68–72, 174). Petitioner asserts that incorporating Doyle’s teachings regarding maintaining a computer readable medium with compatibility information into the multimedia protocol conversion system of Ressa would be no more than combining prior art elements according to known methods to yield predictable results. *Id.* at 65 (citing Ex. 1002, ¶¶ 68–72, 175). Petitioner also asserts that storing information regarding the protocols used by a communication device, as in Doyle, was routine functionality that a person of ordinary skill in the art would understand well. *Id.* Petitioner also argues that, for the same reason, the combination of Ressa and Doyle is a use of a known technique with a known device ready for improvement to yield predictable results. *Id.* (citing Ex. 1002 ¶¶ 68–73, 176). Petitioner asserts that Ressa itself suggests retrieving the protocol type from a device information base because the table in Ressa’s Figure 8 contains compatibility information for each device available to the endpoint, so this suggests that Ressa must retrieve that information to assist in protocol conversion. *Id.* at 66 (citing Ex. 1004, 9:46–49; Ex. 1002 ¶¶ 79–80, 174).

We have reviewed Petitioner’s explanations and supporting evidence and find that Petitioner provides sufficient support showing the teachings of the claim 5 limitations by Ressa and Doyle and also has sufficiently supported the rationale to combine the references. We note that Doyle teaches a computer readable medium that collects protocol information, as well as other information such as G.711 audio media. *See* Ex. 1005 ¶¶ 35, 39. Doyle also teaches that the collected protocol information can be analyzed and stored. *Id.* ¶ 13. Accordingly, we agree with Petitioner’s

assertion that the computer readable medium is the claimed “device information base” that contains stored compatibility information for each device available and which also allows retrieval of a second protocol type.

Patent Owner argues that the Petition fails to adequately explain how the protocol information collected by the computer readable medium of Doyle constitutes compatibility information. PO Resp. 46 (citing Ex. 2009, ¶¶ 173–174). Patent Owner further argues that a person of ordinary skill in the art would not have understood Doyle to deal with or store “compatibility information for each device available for said multimedia communication.” *Id.* Patent Owner also argues that the only piece of information identified by Petitioner as being collected by Doyle is the content of the communication (for example, G.711 audio media), but a person of ordinary skill in the art would have understood G.711 to be an audio codec, not a type of protocol. *Id.*

We find that the Petition’s explanation of the collection of data constituting compatibility information is sufficient; claim 5 requires only that compatibility information be stored in the “device information base,” and Petitioner has demonstrated that Doyle teaches collection and storage of a variety of protocol information. *See* Pet. 63–64; Ex. 1005 ¶¶ 13, 35, 39. We also are not persuaded by Patent Owner’s arguments on Doyle’s allegedly deficient teaching of compatibility information. The claimed “compatibility information” is a broad term. We agree with Petitioner that in Doyle the types of protocols and codecs being used by a device are compatibility information because this information is necessary to determine whether two endpoints are compatible. Pet. Reply 24. This assertion is supported by the testimony of Dr. Lavian, which we credit. Ex. 1017 ¶ 37.



Patent Owner additionally argues that Petitioner does not provide adequate support of a rationale to combine because Doyle is not in the same field of endeavor as the claimed invention. PO Resp. 47. Patent Owner asserts that Petitioner presents the same generic rationale for modifying the system of Ress to incorporate Doyle's teaching of as it did with respect to claim limitation 1[b]. *Id.* Patent Owner argues that for similar reasons to those of claim 1, a person of ordinary skill in the art would not have been motivated to combine Ress with Doyle and would not have had a reasonable expectation of success in doing so. *Id.* at 47–48.

We are not persuaded by Patent Owner's arguments. As discussed above for claim 1, we have determined that Doyle is analogous art. Petitioner has provided sufficient evidence that maintaining a computer readable medium with compatibility information and protocol type, as discussed in Doyle, is a predictable variation to Ress and that one of ordinary skill would have had a reasonable expectation of success in making the combination. *See* Pet. 64–66; *see also* *KSR*, 550 U.S. at 416 (“The combination of familiar elements according to known methods is likely to be obvious when it does no more than yield predictable results.”).

We have considered Patent Owner's arguments concerning objective indicia of nonobviousness above. PO Resp. 49–55. For the reasons discussed, we find that Patent Owner's evidence purportedly showing long-felt need, unexpected results, and industry praise, does not outweigh Petitioner's evidence concerning the obviousness of claim 5. On the full record, Petitioner has established by a preponderance of the evidence that claim 5 would have been obvious over the combination of Ress and Doyle.

*c. Claims 7, 10, 11, 15, 18, and 22*

Petitioner presents arguments for claims 7, 10, 11, 15, 18, and 22. Pet. 66–68. We have reviewed Petitioner’s explanations and supporting evidence as to how the combination of Ress and Doyle teach the limitations of claims 7, 10, 11, 15, 18, and 22 and determine that Petitioner has demonstrated that the prior art’s teachings are sufficient, as is the rationale to combine the references.

Patent Owner argues that claims 7, 10, 11, 15, 18, and 22 are not rendered obvious based on the arguments directed to other claims, which we have already considered. PO Resp. 48–49. We do not find these arguments persuasive for the reasons discussed above.

We have considered Patent Owner’s arguments concerning objective indicia of nonobviousness. PO Resp. 49–55. For the reasons discussed above, we find that Patent Owner’s evidence purportedly showing long-felt need, unexpected results, and industry praise does not outweigh Petitioner’s evidence concerning the obviousness of claims 7, 10, 11, 15, 18, and 22. On the full record, Petitioner has established by a preponderance of the evidence that claims 7, 10, 11, 15, 18, and 22 would have been obvious over the combination of Ress and Doyle.

*d. Claims 2–4, 6, 8–9, 12–14, 16–17, 19–21, and 23*

In the introductory portion addressing this ground, the Petition states that “[f]or Ground 2, Petition relies on Ress as discussed above for Ground 1, in view of Doyle.” Pet. 56. The Petition goes on to provide argument specific to claims 1, 5, 7, 10, 11, 15, 18, and 22; identify relevant portions of Doyle; and present related arguments including the rationale to combine Doyle and Ress. *See id.* at 56–68.

Patent Owner argues that because the Petition lacks argument and analysis as to claims 2–4, 6, 8–9, 12–14, 16–17, 19–21, and 23, the challenges to these claims should be rejected by the Board. PO Resp. 40–41 (citing 35 U.S.C. § 312(a)(3); 37 C.F.R. §§ 42.22(a)(2), 42.104(b)(4)–(5); *SAS Inst. Inc. v. Iancu*, 138 S. Ct. 1348, 1356 (2018)).

Petitioner argues that the Petition’s statement that it relies on Ress as discussed in the first ground for the second ground indicates that the second ground presents the same arguments as the first ground, except for those claims where Doyle was added as a secondary reference. Pet. Reply 18–19. Petitioner asserts that all the claims at issue are dependent claims, and there was no need to duplicate arguments for these dependent claims where the analysis has not changed. *Id.*

We decline to reject Petitioner’s assertions for claims 2–4, 6, 8–9, 12–14, 16–17, 19–21, and 23 because the Petition’s statement of the second ground’s reliance on Ress for these dependent claims, as were set forth in the first ground, serves as sufficient notice of the basis for Petitioner’s challenge.

We have reviewed Petitioner’s arguments and evidence and determine that Petitioner has provided sufficient evidence that the combination of Ress and Doyle teaches the limitations of claims 2–4, 6, 8–9, 12–14, 16–17, 19–21, and 23.

We have considered Patent Owner’s arguments concerning objective indicia of nonobviousness. PO Resp. 49–55. For the reasons discussed above, we find that Patent Owner’s evidence purportedly showing long-felt need, unexpected results, and industry praise does not outweigh Petitioner’s evidence concerning the obviousness of claims 2–4, 6, 8–9, 12–14, 16–17, 19–21, and 23. On the full record, Petitioner has established by a

IPR2019-01233

Patent 7,773,588 B2

preponderance of the evidence that claims 2–4, 6, 8–9, 12–14, 16–17, 19–21, and 23 would have been obvious over the combination of Ress and Doyle.

### III. MOTION TO SEAL

Patent Owner filed a Motion to Seal and for Entry of a Protective Order. Paper 31. Patent Owner seeks to seal portions of Exhibit 2008, and a version with the redactions has been filed. *See Ex. 2008*. Patent Owner asserts that Exhibit 2008 contains a claim chart with an identification of highly confidential source for the STNS system, and seeks sealing for that identification. Paper 31, 1. The Motion is unopposed.

We have reviewed the redacted portion of the document, as well as the explanations of the confidential nature of the materials for which sealing is sought, as discussed in the Motion. We grant the Motion and the associated request to enter the Protective Order.

#### IV. CONCLUSION<sup>13</sup>

In summary:

<b>Claims</b>	<b>35 U.S.C. §</b>	<b>Reference(s)/Basis</b>	<b>Claims Shown Unpatentable</b>	<b>Claims Not Shown Unpatentable</b>
1–23	103(a)	Ress	1–4, 6–14, 16–21, 23	5, 15, 22
1–23	103(a)	Ress, Doyle	1–23	
<b>Overall Outcome</b>			1–23	

#### V. ORDER

For the reasons given, it is:

ORDERED that Petitioner has shown by a preponderance of the evidence that claims 1–23 of U.S. Patent No. 7,773,588 B2 are unpatentable;

FURTHER ORDERED that the Motion to Seal (Paper 31) is granted;

FURTHER ORDERED that the request to enter the protective order is granted; and

FURTHER ORDERED because this is a final written decision, the parties to this proceeding seeking judicial review of our Decision must comply with the notice and service requirements of 37 C.F.R. § 90.2.

---

<sup>13</sup> Should Patent Owner wish to pursue amendment of the challenged claims in a reissue or reexamination proceeding subsequent to the issuance of this decision, we draw Patent Owner’s attention to the April 2019 *Notice Regarding Options for Amendments by Patent Owner Through Reissue or Reexamination During a Pending AIA Trial Proceeding*. See 84 Fed. Reg. 16,654 (Apr. 22, 2019). If Patent Owner chooses to file a reissue application or a request for reexamination of the challenged patent, we remind Patent Owner of its continuing obligation to notify the Board of any such related matters in updated mandatory notices. See 37 C.F.R. § 42.8(a)(3), (b)(2).

IPR2019-01233  
Patent 7,773,588 B2

PETITIONER:

John Presper  
Robert Mattson  
Stephen McBride  
Oblon, McClelland, Maier & Neustadt, LLP  
cpdocketpresper@oblon.com  
cpdocketmattson@oblon.com  
cpdocketmcbride@oblon.com

PATENT OWNER:

Jitendra Malik  
Sean S. Wooden  
Christopher Ferenc  
Katten Muchin Rosenman LLP  
jitty.malik@kattenlaw.com  
sean.wooden@kattenlaw.com  
christopher.ferenc@kattenlaw.com